

## INTERNATIONAL APPLICATION PUBLISHED UNDER THE PATENT COOPERATION TREATY (PCT)

(31) International Patent Classification <sup>6</sup> : <b>C12N 15/82, 15/57, 15/15, 15/14, C12P 21/02</b>		A1	(11) International Publication Number: <b>WO 98/36085</b>
			(43) International Publication Date: 20 August 1998 (20.08.98)
(21) International Application Number: PCT/US98/03068		(72) Inventors; and	
(22) International Filing Date: 13 February 1998 (13.02.98)		(75) Inventors/Applicants (for US only): SUTLIFF, Thomas, D. [US/US]; 3405 Cook Street, Rocklin, CA 94765 (US). RODRIGUEZ, Raymond, L. [US/US]; 3017 Anza Boulevard, Davis, CA 95616 (US).	
(30) Priority Data:		(74) Agents: PETITHORY, Joanne, R. et al.; Dehlinger & Associates, LLP, P.O. Box 60850, Palo Alto, CA 94306-0850 (US).	
60/038,169	13 February 1997 (13.02.97)	US	
60/037,991	13 February 1997 (13.02.97)	US	
60/038,170	13 February 1997 (13.02.97)	US	
60/038,168	13 February 1997 (13.02.97)	US	
(63) Related by Continuation (CON) or Continuation-in-Part (CIP) to Earlier Applications		(81) Designated States: AL, AM, AT, AU, AZ, BA, BB, BG, BR, BY, CA, CH, CN, CU, CZ, DE, DK, EE, ES, FI, GB, GE, GH, GM, GW, HU, ID, IL, IS, JP, KE, KG, KP, KR, KZ, LC, LK, LR, LS, LT, LU, LV, MD, MG, MK, MN, MW, MX, NO, NZ, PL, PT, RO, RU, SD, SE, SG, SI, SK, SL, TJ, TM, TR, TT, UA, UG, US, UZ, VN, YU, ZW, ARIPO patent (GH, GM, KE, LS, MW, SD, SZ, UG, ZW), Eurasian patent (AM, AZ, BY, KG, KZ, MD, RU, TJ, TM), European patent (AT, BE, CH, DE, DK, ES, FI, FR, GB, GR, IE, IT, LU, MC, NL, PT, SE), OAPI patent (BF, BJ, CF, CG, CI, CM, GA, GN, ML, MR, NE, SN, TD, TG).	
US	60/038,169 (CIP)		
Filed on	13 February 1997 (13.02.97)		
US	60/037,991 (CIP)		
Filed on	13 February 1997 (13.02.97)		
US	60/038,170 (CIP)		
Filed on	13 February 1997 (13.02.97)		
US	60/038,168 (CIP)		
Filed on	13 February 1997 (13.02.97)		
(71) Applicant (for all designated States except US): APPLIED PHYTOLOGICS, INC. [US/US]; 4110 North Freeway Boulevard, Sacramento, CA 95834-1219 (US).		Published With international search report. Before the expiration of the time limit for amending the claims and to be republished in the event of the receipt of amendments.	

(54) Title: PRODUCTION OF MATURE PROTEINS IN PLANTS

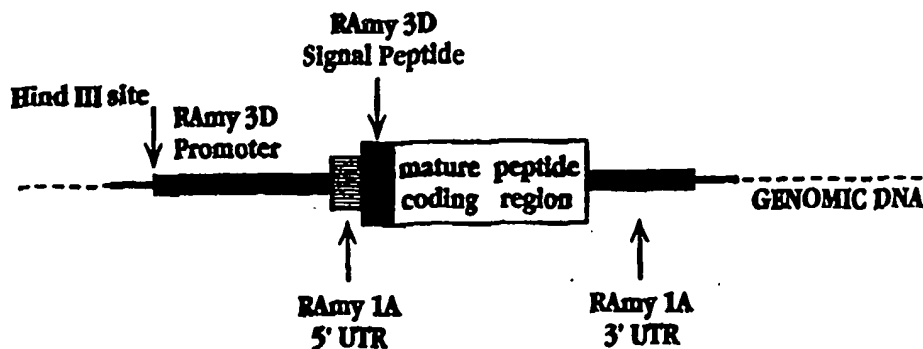

## (57) Abstract

A method for producing one of the following proteins in transgenic monocot plant cells is disclosed: (i) mature, glycosylated  $\alpha_1$ -antitrypsin (AAT) having the same N-terminal amino acid sequence as mature AAT produced in humans and a glycosylation pattern which increases serum half-life substantially over that of mature non-glycosylated AAT; (ii) mature, glycosylated antithrombin III (ATIII) having the same N-terminal amino acid sequence as mature ATIII produced in humans; (iii) mature human serum albumin (HSA) having the same N-terminal amino acid sequence as mature HSA produced in humans and having the folding pattern of native mature HSA as evidenced by its bilirubin-binding characteristics; and (iv) mature, active subtilisin BPN' (BPN') having the same N-terminal amino acid sequence as BPN' produced in *Bacillus*. Monocot plants cells are transformed with a chimeric gene which includes a DNA coding sequence encoding a fusion protein having an (i) N-terminal moiety corresponding to a rice  $\alpha$ -amylase signal sequence peptide and, (iii) immediately adjacent the C-terminal amino acid of said peptide, a protein moiety corresponding to the mature protein to be produced.

**FOR THE PURPOSES OF INFORMATION ONLY**

Codes used to identify States party to the PCT on the front pages of pamphlets publishing international applications under the PCT.

AL	Albania	ES	Spain	LS	Lesotho	SI	Slovenia
AM	Armenia	FI	Finland	LT	Lithuania	SK	Slovakia
AT	Austria	FR	France	LU	Luxembourg	SN	Senegal
AU	Australia	GA	Gabon	LV	Latvia	SZ	Swaziland
AZ	Azerbaijan	GB	United Kingdom	MC	Monaco	TD	Chad
BA	Bosnia and Herzegovina	GE	Georgia	MD	Republic of Moldova	TG	Togo
BB	Barbados	GH	Ghana	MG	Madagascar	TJ	Tajikistan
BE	Belgium	GN	Guinea	MK	The former Yugoslav Republic of Macedonia	TM	Turkmenistan
BF	Burkina Faso	GR	Greece			TR	Turkey
BG	Bulgaria	HU	Hungary	ML	Mali	TT	Trinidad and Tobago
BJ	Benin	IE	Ireland	MN	Mongolia	UA	Ukraine
BR	Brazil	IL	Israel	MR	Mauritania	UG	Uganda
BY	Belarus	IS	Iceland	MW	Malawi	US	United States of America
CA	Canada	IT	Italy	MX	Mexico	UZ	Uzbekistan
CF	Central African Republic	JP	Japan	NE	Niger	VN	Viet Nam
CG	Congo	KE	Kenya	NL	Netherlands	YU	Yugoslavia
CH	Switzerland	KG	Kyrgyzstan	NO	Norway	ZW	Zimbabwe
CI	Côte d'Ivoire	KP	Democratic People's Republic of Korea	NZ	New Zealand		
CM	Cameroon			PL	Poland		
CN	China	KR	Republic of Korea	PT	Portugal		
CU	Cuba	KZ	Kazakstan	RO	Romania		
CZ	Czech Republic	LC	Saint Lucia	RU	Russian Federation		
DE	Germany	LI	Liechtenstein	SD	Sudan		
DK	Denmark	LK	Sri Lanka	SE	Sweden		
EE	Estonia	LR	Liberia	SG	Singapore		

## Production of Mature Proteins in Plants

### Field of the Invention

The present invention relates to the production of mature proteins in plant cells, and in particular, to the production of proteins in mature secreted form.

5

### Background of the Invention

A major commercial focus of biotechnology is the recombinant production of proteins, including both industrial enzymes and proteins that have important therapeutic uses.

10 Therapeutic proteins are commonly produced recombinantly by microbial expression systems, such as in *E. coli* and the yeast system *S. cerevisiae*. To date, the cost of recombinant proteins produced in a microbial host has limited the availability of a variety of therapeutically important proteins, such as human serum albumin (HSA) and  $\alpha_1$ -antitrypsin (AAT), to the extent that the proteins are in short supply.

15 Some therapeutic proteins appear to rely on glycosylation for optimal activity or stability, and the general inability of microbial systems to glycosylate or properly glycosylate mammalian proteins has also limited the usefulness of these recombinant expression systems. In some cases, proper protein folding cannot take place, because of the need for mammalian-specific foldases or other folding conditions.

20 To some extent, protein expression in cultured mammalian cells, or in transgenic animals may overcome the limitations of microbial expression systems. However, the cost per weight ratio of the protein is still high in mammalian expression systems, and the risk of protein contamination by mammalian viruses may be a significant regulatory problem. Protein production by transgenic animals also carries the risk of genetic variation from one generation to another. The attendant risk is variation in the recombinant protein produced, for example, variation in protein processing to  
25 yield a nature active protein with different N-terminal residue.

It would therefore be desirable to produce selected therapeutic and industrial proteins in a protein expression system that largely overcomes problems associated with microbial and mammalian-cell systems. In particular, production of the proteins should allow large volume production at low cost, and yield properly processed and glycosylated proteins. The production  
30 system should also have a relatively stable genotype from generation to generation. These aims are achieved, in the present invention, for the therapeutic proteins AAT, HSA, and antithrombin III (ATIII), and the industrial enzyme subtilisin BPN'.

### Human $\alpha_1$ -antitrypsin

Human  $\alpha_1$ -antitrypsin (AAT) is a monomer with a molecular weight of about 52Kd. Normal AAT contains 394 residues, with three complex oligosaccharide units exposed to the surface of the  
5 molecule, linked to asparagines 46, 83, and 247 (Carrell, P., *et al.*, *Nature* (1982) 298:329).

AAT is the major plasma proteinase inhibitor whose primary function is to control the proteolytic activity of trypsin, elastase, and chymotrypsin in plasma. In particular, the protein is a potent inhibitor of neutrophil elastase, and a deficiency of AAT has been observed in a number of  
10 patients with chronic emphysema of the lungs. A proportion of individuals with serum deficiency of AAT may progress to cirrhosis and liver failure (*e.g.*, Wu, Y., *et al.*, *BioEssays* 13(4):163 (1991)).

Because of the key role of AAT as an elastase inhibitor, and because of the prevalence of genetic diseases resulting in deficient serum levels of AAT, there has been an active interest in  
15 recombinant synthesis of AAT, for human therapeutic use. To date, this approach has not been satisfactory for AAT produced by recombinant methods, for the reasons discussed above.

### Human Antithrombin III

Antithrombin III (ATIII) is the major inhibitor of thrombin and factor Xa, and to a lesser extent, other serine proteases generated during the coagulation process, *e.g.*, factors IXa, XIa, and  
20 XIIa. The inhibitory effect of ATIII is accelerated dramatically by heparin. In patients with a history of deep vein thrombosis and pulmonary embolism, the prevalence of ATIII deficiency is 2-3%.

ATIII protein has been useful in treating hereditary ATIII deficiency and has wide clinical applications for the prevention of thrombosis in high risk situations, such as surgery and delivery,  
25 and for treating acute thrombotic episodes, when used in combination with heparin.

ATIII is a glycoprotein with a molecular weight of 58,200, having 432 amino acids and containing three disulfide linkages and four asparagine-linked biantennary carbohydrate chains. Because of the key role of ATIII as an anti-thrombotic agent, and because of the broad clinical potential in anti-thrombosis therapy, there has been an active interest in recombinant synthesis of  
30 ATIII, for human therapeutic use. To date, this approach has not been satisfactory for ATIII produced by microbial or mammalian recombinant methods, for the reasons discussed above.

### Human Serum Albumin

Serum albumin is the main protein component of plasma. Its main function is regulation of colloidal osmotic pressure in the bloodstream. Serum albumin binds numerous ions and small  
35 molecules, including  $\text{Ca}^{2+}$ ,  $\text{Na}^+$ ,  $\text{K}^+$ , fatty acids, hormones, bilirubin and certain drugs.

Human serum albumin (HSA) is expressed as a 609 amino acid prepro-protein which is further processed by removal of an amino-terminal peptide and an additional six amino acid residues to form the mature protein. The mature protein found in human serum is a monomeric, unglycosylated protein 585 amino acids in length (66 kDal), with a globular structure maintained by 17 disulfide bonds. The pattern of disulfide links forms a structural unit of one small and two large disulfide-linked double loops (Geisow, M.J. *et al.* (1977) *Biochem. J.* 163:477-484) which forms a high-affinity bilirubin binding site.

HSA is used to expand blood volume and raise low blood protein levels in cases of shock, trauma, and post-surgical recovery. HSA is often administered in emergency situations to stabilize blood pressure.

Because of the key role of HSA as an osmotic stabilizing agent, and because of its broad clinical potential in, *e.g.*, plasma replacement therapy, there has been an active interest in recombinant synthesis of HSA for human therapeutic use. This approach has not been satisfactory for HSA produced by microbial or mammalian recombinant methods, for the reasons discussed above.

#### Subtilisin BPN'

Subtilisin BPN' (BPN') is an important industrial enzyme, particularly for use as a detergent enzyme. Several groups have reported amino acid substitution modifications of the enzyme that are effective in enhancing the activity, pH optimum, stability and/or therapeutic use of the enzyme.

BPN' is expressed in as a 381 amino acid preproenzyme, including 35 amino acid sequence required for secretion and a 77 amino acid moiety which serves as a chaperon to facilitate folding. Studies indicate that the pro moiety acts in trans outside of cells.

To date, large-scale production of BPN' is predominantly by microbial fermentation, which has relatively high costs associated with it. In addition, the enzyme tends to auto-degrade at optimal fermentation growth-medium conditions.

#### Summary of the Invention

In one aspect, the invention includes a method of producing, in monocot plant cells, a mature heterologous protein selected from the group consisting of (i) mature, glycosylated  $\alpha_1$ -antitrypsin (AAT) having the same N-terminal amino acid sequence as mature AAT produced in humans and a glycosylation pattern which increases serum halflife substantially over that of non-glycosylated mature AAT; (ii) mature, glycosylated antithrombin III (ATIII) having the same N-terminal amino acid sequence as mature ATIII produced in humans; (iii) mature human serum albumin (HSA) having the same N-terminal amino acid sequence as mature HSA produced in

humans and having the folding pattern of native mature HSA as evidenced by its bilirubin-binding characteristics; and (iv) mature, active subtilisin BPN' (BPN'), glycosylated or non-glycosylated, having the same N-terminal amino acid sequence as BPN' produced in *Bacillus*.

The method includes obtaining monocot cells transformed with a chimeric gene having (i) a monocot transcriptional regulatory region, inducible by addition or removal of a small molecule, or during seed maturation, (ii) a first DNA sequence encoding the heterologous protein, and (iii) a second DNA sequence encoding a signal peptide. The second DNA sequence is operably linked to the transcriptional regulatory region and to the first DNA sequence. The first DNA sequence is in translation-frame with the second DNA sequence, and the two sequences encode a fusion protein. The transformed cells are cultivated under conditions effective to induce the transcriptional regulatory region, thereby promoting expression of the fusion protein and secretion of the mature heterologous protein from the transformed cells. The mature heterologous protein produced by the transformed cells is then isolated.

In one embodiment of the method, the first DNA sequence encodes pro-subtilisin BPN' (proBPN'), the cultivating includes cultivating the transformed cells at a pH between 5 and 6, and the isolating step includes incubating the proBPN' to under condition effective to allow its autoconversion to active mature BPN'. In another embodiment, the first DNA sequence encodes mature BPN', and the cells are transformed with a second chimeric gene containing (i) a transcriptional regulatory region inducible by addition or removal of a small molecule, (ii) a third DNA sequence encoding the pro-peptide moiety of BPN', and (iii) a fourth DNA sequence encoding a signal polypeptide. The fourth DNA sequence is operably linked to the transcriptional regulatory region and to the third DNA sequence, and the signal polypeptide is in translation-frame with the pro-peptide moiety and is effective to facilitate secretion of expressed pro-peptide moiety from the transformed cells. The cultivating step includes cultivating the transformed cells at a pH between 5 and 6, and the isolating step includes incubating the mature BPN' and the pro-moiety under conditions effective to allow the conversion of BPN' by the pro- moiety to active mature BPN'.

In another embodiment of the method, the signal peptide is the RAmy3D signal peptide (SEQ ID NO:1) or the RAmy1A signal peptide (SEQ ID NO:4). The coding sequence of the signal peptide may be a codon-optimized sequence, such as the codon-optimized RAmy3D sequence identified as SEQ ID NO:3. The first DNA sequence may also be codon-optimized. Exemplary codon-optimized signal peptide-heterologous protein fusion protein coding sequences include 3D-AAT (SEQ ID NO:18), 3D-ATIII (SEQ ID NO:19), and 3D-HSA (SEQ ID NO:20). The first DNA sequence may further contain codon substitutions which eliminate one or more potential glycosylation sites present in the native amino acid sequence of the heterologous protein, such as the codon-optimized sequence encoding 3D-proBPN' (SEQ ID NO:21).

In other embodiments of the method, the transcriptional regulatory region may be a promoter derived from a rice or barley  $\alpha$ -amylase gene, including RAmy1A, RAmy1B, RAmy2A, RAmy3A, RAmy3B, RAmy3C, RAmy3D, RAmy3E, pM/C, gKAmy141, gKAmy155, Amy32b, or HV18. The chimeric gene may further include, between the transcriptional regulatory region and the fusion protein coding sequence, the 5' untranslated region (5' UTR) of an inducible monocot gene such as one of the rice or barley  $\alpha$ -amylase genes described above. One preferred 5' UTR is that from the RAmy1A gene, which is effective to enhance the stability of the gene transcript. The chimeric gene may further include, downstream of the coding sequence, the 3' untranslated region (3' UTR) from an inducible monocot gene, such as one of the rice or barley  $\alpha$ -amylase genes mentioned above. One preferred 3' UTR is from the RAmy1A gene.

Where the method is employed in protein production in a monocot cell culture, preferred promoters are the RAmy3D and RAmy3E gene promoters, which are upregulated by sugar depletion in cell culture. Where the gene is employed in protein production in germinating seeds, a preferred promoter is the RAmy1A gene promoter, which is upregulated by gibberellic acid during seed germination. Where gene is upregulated during seed maturation, a preferred promoter is the barley endosperm-specific B1-hordein promoter.

The invention also includes a mature heterologous protein produced by the above method. The protein has a glycosylation pattern characteristic of the monocot plant in which the protein is produced. The glycosylated protein is selected from the group consisting of (i) mature glycosylated  $\alpha_1$ -antitrypsin (AAT) having the same N-terminal amino acid sequence as mature AAT produced in humans and having a glycosylation pattern which increases serum half-life substantially over that of non-glycosylated mature AAT; (ii) mature glycosylated antithrombin III (ATIII) having the same N-terminal amino acid sequence as mature ATIII produced in humans; and (iii) mature glycosylated subtilisin BPN' (BPN') having the same N-terminal amino acid sequence as BPN' produced in *Bacillus*.

The invention also includes plant cells and seeds capable of producing the mature heterologous proteins according to the above method.

These and other objects and features of the invention will be more fully understood when the following detailed description of the invention is read in conjunction with the accompanying drawings.

#### Brief Description of the Figures

Fig. 1 shows, in the lower row, the amino acid sequence of a RAmy3D signal sequence portion employed in the invention, identified as SEQ ID NO:1; in the middle row, the corresponding native coding sequence, identified as SEQ ID NO:2; and in the upper row, a corresponding codon-optimized sequence, identified as SEQ ID NO:3;

Fig. 2 illustrates the components of a chimeric gene constructed in accordance with an embodiment of the invention;

Figs. 3A and 3B illustrate the construction of an exemplary transformation vector for use in transforming a monocot plant, for production of a mature protein in cell culture in accordance with one embodiment of the invention (native mature AAT coding sequence under control of the  
5 RAmY3D promoter and signal sequence);

Fig. 4 illustrates factors in the metabolic regulation of AAT production in rice cell culture;

Fig. 5 shows immunodetection of AAT using antibody raised against the C-terminal region of AAT;

10 Fig. 6 shows Western blot analysis of AAT produced by transformed rice cell lines 18F, 11B, and 27F;

Fig. 7 shows the time course of elastase:AAT complex formation in human and rice-produced forms of AAT;

Fig. 8 shows an N-terminal sequence for mature  $\alpha_1$ -antitrypsin (AAT) produced in  
15 accordance with the invention, identified herein as SEQ ID NO:22;

Fig. 9 shows a Western blot of ATIII produced in accordance with the invention;

Fig. 10 shows a Western blot of plant-produced BPN', comparing expression from codon-optimized and native coding sequences;

Fig. 11 compares the specific activity of BPN' codon-optimized (AP106) vs. BPN' native  
20 (AP101) expression in rice callus cell culture; and

Fig. 12 shows a western blot of HSA produced in germinating seeds in accordance with the invention.

#### Brief Description of the Sequences

- 25 SEQ ID NO:1 is the amino acid sequence of the RAmY3D signal peptide;  
SEQ ID NO:2 is the native sequence encoding the RAmY3D signal peptide;  
SEQ ID NO:3 is a codon-optimized sequence encoding the RAmY3D signal peptide;  
SEQ ID NO:4 is the amino acid sequence of the RAmY1A signal peptide;  
SEQ ID NO:5 is the 5' UTR derived from the RAmY1A gene;  
30 SEQ ID NO:6 is the 3' UTR derived from the RAmY1A gene;  
SEQ ID NO:7 is the amino acid sequence of mature  $\alpha_1$ -antitrypsin (AAT);  
SEQ ID NO:8 is the native DNA coding sequence of mature AAT;  
SEQ ID NO:9 is the amino acid sequence of mature antithrombin III (ATIII);  
SEQ ID NO:10 is the native DNA coding sequence of mature ATIII;  
35 SEQ ID NO:11 is the amino acid sequence of mature human serum albumin (HSA);



SEQ ID NO:12 is the native DNA coding sequence of mature HSA;  
SEQ ID NO:13 is the amino acid sequence of native proBPN';  
SEQ ID NO:14 is the native DNA coding sequence of proBPN';  
SEQ ID NO:15 is the amino acid sequence of the "pro" moiety of BPN';  
5 SEQ ID NO:16 is the amino acid sequence of native mature BPN';  
SEQ ID NO:17 is the amino acid sequence of a mature BPN' variant in which all potential  
N-glycosylation sites are removed according to Table 2;  
SEQ ID NO:18 is a codon-optimized sequence encoding the RAmy3D signal  
sequence/mature  $\alpha_1$ -antitrypsin fusion protein;  
10 SEQ ID NO:19 is a sequence encoding the RAmy3D signal sequence/mature antithrombin  
III fusion protein, with a codon-optimized RAmy3D coding sequence fused to the native mature  
ATIII coding sequence;  
SEQ ID NO:20 is a sequence encoding the RAmy3D signal sequence/mature human serum  
albumin fusion protein, with a codon-optimized RAmy3D coding sequence fused to the native  
15 mature HSA coding sequence;  
SEQ ID NO:21 is a codon-optimized sequence encoding the RAmy3D signal  
sequence/prosubtilisin BPN' fusion protein;  
SEQ ID NO:22 is the N-terminal sequence of mature  $\alpha_1$ -antitrypsin produced in accordance  
with the invention;  
20 SEQ ID NO:23 is an oligonucleotide used to prepare the intermediate p3DProSig construct  
of Example 1;  
SEQ ID NO:24 is the complement of SEQ ID NO:23;  
SEQ ID NO:25 is an oligonucleotide used to prepare the intermediate p3DProSigENDlink  
construct of Example 1;  
25 SEQ ID NO:26 is the complement of SEQ ID NO:25;  
SEQ ID NO:27 is one of six oligonucleotides used to prepare the intermediate p1AProSig  
construct of Example 1;  
SEQ ID NO:28 is one of six oligonucleotides used to prepare the intermediate p1AProSig  
construct of Example 1;  
30 SEQ ID NO:29 is one of six oligonucleotides used to prepare the intermediate p1AProSig  
construct of Example 1;  
SEQ ID NO:30 is one of six oligonucleotides used to prepare the intermediate p1AProSig  
construct of Example 1;  
35 SEQ ID NO:31 is one of six oligonucleotides used to prepare the intermediate p1AProSig  
construct of Example 1;

SEQ ID NO:32 is one of six oligonucleotides used to prepare the intermediate p1AProSig construct of Example 1;

SEQ ID NO:33 is the N-terminal primer used to PCR-amplify the AAT coding sequence according to Example 1; and

5 SEQ ID NO:34 is the C-terminal primer used to PCR-amplify the AAT coding sequence according to Example 1.

### Detailed Description of the Invention

#### I. Definitions:

10 The terms below have the following meaning, unless indicated otherwise in the specification.

"Cell culture" refers to cells and cell clusters, typically callus cells, growing on or suspended in a suitable growth medium.

15 "Germination" refers to the breaking of dormancy in a seed and the resumption of metabolic activity in the seed, including the production of enzymes effective to break down starches in the seed endosperm.

"Inducible" means a promoter that is upregulated by the presence or absence of a small molecules. It includes both indirect and direct inducement.

20 "Inducible during germination" refers to promoters which are substantially silent but not totally silent prior to germination but are turned on substantially (greater than 25%) during germination and development in the seed. Examples of promoters that are inducible during germination are presented below.

25 "Small molecules", in the context of promoter induction, are typically small organic or bioorganic molecules less than about 1 kDal. Examples of such small molecules include sugars, sugar-derivatives (including phosphate derivatives), and plant hormones (such as, gibberellic or absissic acid).

30 "Specifically regulatable" refers to the ability of a small molecule to preferentially affect transcription from one promoter or group of promoters (e.g., the  $\alpha$ -amylase gene family), as opposed to non-specific effects, such as, enhancement or reduction of global transcription within a cell by a small molecule.

35 "Seed maturation" or "grain development" refers to the period starting with fertilization in which metabolizable reserves, e.g., sugars, oligosaccharides, starch, phenolics, amino acids, and proteins, are deposited, with and without vacuole targeting, to various tissues in the seed (grain), e.g., endosperm, testa, aleurone layer, and scutellar epithelium, leading to grain enlargement, grain filling, and ending with grain desiccation.

"Inducible during seed maturation" refers to promoters which are turned on substantially (greater than 25%) during seed maturation.

"Heterologous DNA" or "foreign DNA" refers to DNA which has been introduced into plant cells from another source, or which is from a plant source, including the same plant source, but which is under the control of a promoter or terminator that does not normally regulate expression of the heterologous DNA.

"Heterologous protein" is a protein, including a polypeptide, encoded by a heterologous DNA. A "transcription regulatory region" or "promoter" refers to nucleic acid sequences that influence and/or promote initiation of transcription. Promoters are typically considered to include regulatory regions, such as enhancer or inducer elements.

A "chimeric gene," in the context of the present invention, typically comprises a promoter sequence operably linked to DNA sequence that encodes a heterologous gene product, *e.g.*, a selectable marker gene or a fusion protein gene. A chimeric gene may also contain further transcription regulatory elements, such as transcription termination signals, as well as translation regulatory signals, such as, termination codons.

"Operably linked" refers to components of a chimeric gene or an expression cassette that function as a unit to express a heterologous protein. For example, a promoter operably linked to a heterologous DNA, which encodes a protein, promotes the production of functional mRNA corresponding to the heterologous DNA.

A "product" encoded by a DNA molecule includes, for example, RNA molecules and polypeptides.

"Removal" in the context of a metabolite includes both physical removal as by washing and the depletion of the metabolite through the absorption and metabolizing of the metabolite by the cells.

"Substantially isolated" is used in several contexts and typically refers to the at least partial purification of a protein or polypeptide away from unrelated or contaminating components. Methods and procedures for the isolation or purification of proteins or polypeptides are known in the art.

"Stably transformed" as used herein refers to a cereal cell or plant that has foreign nucleic acid stably integrated into its genome which is transmitted through multiple generations.

" $\alpha_1$ -antitrypsin" or "AAT" refers to the protease inhibitor which has an amino acid sequence substantially identical or homologous to AAT protein identified by SEQ ID NO:7.

"Antithrombin III" or "ATIII" refers to the heparin-activated inhibitor of thrombin and factor Xa, and which has an amino acid sequence substantially identical or homologous to ATIII protein identified by SEQ ID NO:9.

"Human serum albumin" or "HSA" refers to a protein which has an amino acid sequence substantially identical or homologous to the mature HSA protein identified by SEQ ID NO:11.

"Subtilisin" or "subtilisin BPN" or "BPN" refers to the protease enzyme produced naturally by *B. amyloliquefaciens*, and having the sequence of SEQ ID NO:16, or a sequence homologous therewith.

"proBPN" refers to a form of BPN' having an approximately 78 amino-acid "pro" moiety that functions as a chaperon polypeptide to assist in folding and activation of the BPN', and having the sequence in SEQ ID NO:13, or a sequence homologous therewith.

"Codon optimization" refers to changes in the coding sequence of a gene to replace native codons with those corresponding to optimal codons in the host plant.

A DNA sequence is "derived from" a gene, such as a rice or barley  $\alpha$ -amylase gene, if it corresponds in sequence to a segment or region of that gene. Segments of genes which may be derived from a gene include the promoter region, the 5' untranslated region, and the 3' untranslated region of the gene.

## II. Transformed plant cells

The plants used in the process of the present invention are derived from monocots, particularly the members of the taxonomic family known as the Gramineae. This family includes all members of the grass family of which the edible varieties are known as cereals. The cereals include a wide variety of species such as wheat (*Triticum sps.*), rice (*Oryza sps.*) barley (*Hordeum sps.*) oats, (*Avena sps.*) rye (*Secale sps.*), corn (*Zea sps.*) and millet (*Pennisetum sps.*). In the present invention, preferred family members are rice and barley.

Plant cells or tissues derived from the members of the family are transformed with expression constructs (*i.e.*, plasmid DNA into which the gene of interest has been inserted) using a variety of standard techniques (*e.g.*, electroporation, protoplast fusion or microparticle bombardment). The expression construct includes a transcription regulatory region (promoter) whose transcription is specifically upregulated by the presence or absence of a small molecule, such as the reduction or depletion of sugar, *e.g.*, sucrose, in culture medium, or in plant tissues, *e.g.*, germinating seeds. In the present invention, particle bombardment is the preferred transformation procedure.

The construct also includes a gene encoding a mature heterologous protein in a form suitable for secretion from plant cells. The gene encoding the recombinant heterologous protein is placed under the control of a metabolically regulated promoter. Metabolically regulated promoters are those in which mRNA synthesis or transcription, is repressed or upregulated by a small metabolite or hormone molecule, such as the rice RAmy3D and RAmy3E promoters, which are

upregulated by sugar-depletion in cell culture. For protein production in germinating seeds from regenerated transgenic plants, a preferred promoter is the Ramy 1A promoter, which is up-regulated by gibberellic acid during seed germination. The expression construct also utilizes additional regulatory DNA sequences *e.g.*, preferred codons, termination sequences, to promote efficient translation of AAT, as will be described.

#### A. Plant Expression Vector

Expression vectors for use in the present invention comprise a chimeric gene (or expression cassette), designed for operation in plants, with companion sequences upstream and downstream from the expression cassette. The companion sequences will be of plasmid or viral origin and provide necessary characteristics to the vector to permit the vectors to move DNA from bacteria to the desired plant host. Suitable transformation vectors are described in related application PCT WO 95/14099, published May 25, 1995, which is incorporated by reference herein. Suitable components of the expression vector, including an inducible promoter, coding sequence for a signal peptide, coding sequence for a mature heterologous protein, and suitable termination sequences are discussed below. One exemplary vector is the p3D(AAT)v1.0 vector illustrated in Figs 3A and 3B.

##### A1. Promoters

The transcription regulatory or promoter region is chosen to be regulated in a manner allowing for induction under selected cultivation conditions, *e.g.*, sugar depletion in culture or water uptake followed by gibberellic acid production in germinating seeds. Suitable promoters, and their method of selection are detailed in above-cited PCT application WO 95/14099. Examples of such promoters include those that transcribe the cereal  $\alpha$ -amylase genes and sucrose synthase genes, and are repressed or induced by small molecules, like sugars, sugar depletion or phytohormones such as gibberellic acid or abscisic acid. Representative promoters include the promoters from the rice  $\alpha$ -amylase RAmy1A, RAmy1B, RAmy2A, RAmy3A, RAmy3B, RAmy3C, RAmy3D, and RAmy3E genes, and from the pM/C, gKAm141, gKAm155, Amy32b, and HV18 barley  $\alpha$ -amylase genes. These promoters are described, for example, in ADVANCES IN PLANT BIOTECHNOLOGY Ryu, D.D.Y., *et al*, Eds., Elsevier, Amsterdam, 1994, p.37, and references cited therein. Other suitable promoters include the sucrose synthase and sucrose-6-phosphate-synthetase (SPS) promoters from rice and barley.

Other suitable promoters include promoters which are regulated in a manner allowing for induction under seed-maturation conditions. Examples of such promoters include those associated with the following monocot storage proteins: rice glutelins, oryzins, and prolamines, barley hordeins, wheat gliadins and glutelins, maize zeins and glutelins, oat glutelins, and sorghum

kafirins, millet pennisetins, and rye secalins.

A preferred promoter for expression in germinating seeds is the rice  $\alpha$ -amylase RAm $\alpha$ 1A promoter, which is upregulated by gibberellic acid. Preferred promoters for expression in cell culture are the rice  $\alpha$ -amylase RAm $\alpha$ 3D and RAm $\alpha$ 3E promoters which are strongly upregulated by sugar depletion in the culture. These promoters are also active during seed germination. A preferred promoter for expression in maturing seeds is the barley endosperm-specific B1-hordein promoter (Brandt, A., *et al.*, (1985) Carlsberg Res. Commun. 50:333-345).

The chimeric gene may further include, between the promoter and coding sequences, the 5' untranslated region (5' UTR) of an inducible monocot gene, such as the 5' UTR derived from one of the rice or barley  $\alpha$ -amylase genes mentioned above. One preferred 5' UTR is that derived from the RAm $\alpha$ 1A gene, which is effective to enhance the stability of the gene transcript. This 5' UTR has the sequence given by SEQ ID NO:5 herein.

#### A2. Signal Sequences

In addition to encoding the protein of interest, the chimeric gene encodes a signal sequence (or signal peptide) that allows processing and translocation of the protein, as appropriate. Suitable signal sequences are described in above-referenced PCT application WO 95/14099. One preferred signal sequence is identified as SEQ ID NO:1 and is derived from the RAm $\alpha$ 3D promoter. Another preferred signal sequence is identified as SEQ ID NO:4 and is derived from the RAm $\alpha$ 1A promoter. The plant signal sequence is placed in frame with a heterologous nucleic acid encoding a mature protein, forming a construct which encodes a fusion protein having an N-terminal region corresponding to the signal peptide and, immediately adjacent to the C-terminal amino acid of the signal peptide, the N-terminal amino acid of the mature heterologous protein. The expressed fusion protein is subsequently secreted and processed by signal peptidase cleavage precisely at the junction of the signal peptide and the mature protein, to yield the mature heterologous protein.

In another embodiment of the invention, the coding sequence in the fusion protein gene, in at least the coding region for the signal sequence, may be codon-optimized for optimal expression in plant cells, *e.g.*, rice cells, as described below. The upper row in Fig. 1 shows one codon-optimized coding sequence for the RAm $\alpha$ 3D signal sequence, identified herein as SEQ ID NO:3.

#### A3. Naturally-Occurring Heterologous Protein Coding Sequences

(i)  $\alpha$ <sub>1</sub>-Antitrypsin: Mature human AAT is composed of 394 amino acids, having the sequence identified herein as SEQ ID NO:7. The protein has N-glycosylation sites at asparagines 46, 83 and 247. The corresponding native DNA coding sequence is identified herein as SEQ ID NO:8.

(ii) Antithrombin III: Mature human ATIII is composed of 432 amino acids, having the sequence identified herein as SEQ ID NO:9. The protein has N-glycosylation sites at the four asparagine residues 96, 135, 155, and 192. The corresponding native DNA coding sequence is identified herein as SEQ ID NO:10.

5 (iii) Human serum albumin: Mature HSA as found in human serum is composed of 585 amino acids, having the sequence identified herein as SEQ ID NO:11. The protein has no N-linked glycosylation sites. The corresponding native DNA coding sequence is identified herein as SEQ ID NO:12.

10 (iv) Subtilisin BPN': Native proBPN' as produced in *B. amyloliquefaciens* is composed of 352 amino acids, having the sequence identified herein as SEQ ID NO:13, The corresponding native DNA coding sequence is identified herein as SEQ ID NO:14. The proBPN' polypeptide contains a 77 amino acid "pro" moiety which is identified herein as SEQ ID NO:15. The remainder of the polypeptide, which forms the mature active BPN', is a 275 amino acid sequence identified herein by SEQ ID NO:16. Native BPN' as produced in *Bacillus* is not glycosylated.

15

#### A4. Codon-Optimized Coding Sequences

In accordance with one aspect of the invention, it has been discovered that a severalfold enhancement of expression level can be achieved in plant cell culture by modifying the native coding sequence of a heterologous gene by contain predominantly or exclusively, highest-frequency codons found in the plant cell host.

20 The method will be illustrated for expression of a heterologous gene in rice plant cells, it being recognized that the method is generally applicable to any monocot. As a first step, a representative set of known coding gene sequence from rice is assembled. The sequences are then analyzed for codon frequency for each amino acid, and the most frequent codon is selected for each amino acid. This approach differs from earlier reported codon matching methods, in which more than one frequent codon is selected for at least some of the amino acids. The optimal codons selected in this manner for rice and barley are shown in Table 1.

**Table 1**

Amino Acid	Rice Preferred Codon	Barley Preferred Codon
Ala A	GCC	
Arg R	CGC	
Asn N	AAC	

30

Amino Acid	Rice Preferred Codon	Barley Preferred Codon
Asp D	GAC	
Cys C	UGC	
Gln Q	CAG	
Glu E	GAG	
Gly G	GGC	
His H	CAC	
Ile I	AUC	
Leu L	CUC	
Lys K	AAG	
Phe F	UUC	
Pro P	CCG	CCC
Ser S	AGC	UCC
Thr T	ACC	
Tyr Y	UAC	
Val V	GUC	GUG
stop	UAA	UGA

As indicated above, the fusion protein coding sequence in the chimeric gene is constructed such that the final (C-terminal) codon in the signal sequence is immediately followed by the codon for the N-terminal amino acid in the mature form of the heterologous protein. Exemplary fusion protein genes, in accordance with the present invention, are identified herein as follows:

SEQ ID NO:18, corresponding to codon-optimized coding sequences of the fusion protein consisting of RAmy3D signal sequence/mature  $\alpha_1$ -antitrypsin;

SEQ ID NO:19, corresponding to the fusion protein coding sequence consisting of the codon-optimized RAmy3D signal sequence and the native mature antithrombin III sequence;

SEQ ID NO:20, corresponding to the fusion protein coding sequence consisting of the codon-optimized RAmy3D signal sequence and the native mature human serum albumin sequence;

SEQ ID NO:21, corresponding to codon-optimized coding sequence of the fusion protein RAmy3D signal sequence/prosubtilisin BPN'. In this instance, prosubtilisin is considered the "mature" protein, in that secreted prosubtilisin can autocatalyze to active, mature subtilisin.

In a preferred embodiment, the BPN' coding sequence is further modified to eliminate



potential N-glycosylation sites, as native BPN' is not glycosylated. Table 2 illustrates preferred codon substitutions, which eliminate all potential N-glycosylation sites in subtilisin BPN'. SEQ ID NO:17 corresponds to a mature BPN' amino acid sequence containing the substitutions presented in Table 2.

5

**Table 2**

N-Glycosylation Sites	Location (Asn) (in mature protein)	Amino Acid Substitution
Asn Asn Ser	61	Thr Asn Ser
Asn Asn Ser	76	Thr Asn Ser
Asn Met Ser	123	Thr Met Ser
Asn Gly Thr	218	Ser Gly Thr <sup>1</sup>
Asn Trp Thr	240	Thr Trp Thr

<sup>1</sup>improved thermostability; Bryan, *et al.*, *Proteins: Structure, Function, and Genetics* 1:326 (1986).

10

A5. Transcription and Translation Terminators

The chimeric gene may also include, downstream of the coding sequence, the 3' untranslated region (3' UTR) from an inducible monocot gene, such as one of the rice or barley  $\alpha$ -amylase genes mentioned above. One preferred 3' UTR is that derived from the RAmy1A gene, whose sequence is given by SEQ ID NO:6. This sequence includes non-coding sequence 5' to the polyadenylation site, the polyadenylation site, and the transcription termination sequence. The transcriptional termination region may be selected, particularly for stability of the mRNA to enhance expression. Polyadenylation tails (Alber and Kawasaki, 1982, *Mol. and Appl. Genet.* 1:419-434) are also commonly added to the expression cassette to optimize high levels of transcription and proper transcription termination, respectively. Polyadenylation sequences include but are not limited to the *Agrobacterium* octopine synthetase signal (Gielen, *et al.*, *EMBO J.* 3:835-846 (1984) or the nopaline synthase of the same species (Depicker, *et al.*, *Mol. Appl. Genet.* 1:561-573 (1982).

Since the ultimate expression of the heterologous protein will be in a eukaryotic cell (in this case, a member of the grass family), it is desirable to determine whether any portion of the cloned gene contains sequences which will be processed out as introns by the host's splicing machinery. If so, site-directed mutagenesis of the "intron" region may be conducted to prevent losing a portion of the genetic message as a false intron code (Reed and Maniatis, *Cell* 41:95-105 (1985).

Fig. 2 shows the elements of one preferred chimeric gene constructed in accordance with the invention, and intended particularly for use in protein expression in a rice cell suspension culture. The gene includes, in a 5' to 3' direction, the promoter from the RAmy3D gene, which is inducible in cell culture with sugar depletion, the 5' UTR from the RAmy1A gene, which confers enhanced stability on the gene transcript, the RAmy3D signal sequence coding region, as identified above, the coding region of a heterologous protein to be produced, and a 3' UTR region from the RAmy1A gene.

### III. Plant Transformation

For transformation of plants, the chimeric gene is placed in a suitable expression vector designed for operation in plants. The vector includes suitable elements of plasmid or viral origin that provide necessary characteristics to the vector to permit the vectors to move DNA from bacteria to the desired plant host. Suitable transformation vectors are described in related application PCT WO 95/14099, published May 25, 1995, which is incorporated by reference herein. Suitable components of the expression vector, including the chimeric gene described above, are discussed below. One exemplary vector is the p3Dv1.0 vector described in Example 1.

#### A. Transformation Vector

Vectors containing a chimeric gene of the present invention may also include selectable markers for use in plant cells (such as the *nptII* kanamycin resistance gene, for selection in kanamycin-containing or the phosphinothricin acetyltransferase gene, for selection in medium containing phosphinothricin (PPT)).

The vectors may also include sequences that allow their selection and propagation in a secondary host, such as sequences containing an origin of replication and a selectable marker such as antibiotic or herbicide resistance genes, *e.g.*, HPH (Hagio *et al.*, *Plant Cell Reports* 14:329 (1995); van der Elzer, *Plant Mol. Biol.* 5:299-302 (1985). Typical secondary hosts include bacteria and yeast. In one embodiment, the secondary host is *Escherichia coli*, the origin of replication is a *colE1*-type, and the selectable marker is a gene encoding ampicillin resistance. Such sequences are well known in the art and are commercially available as well (*e.g.*, Clontech, Palo Alto, CA; Stratagene, La Jolla, CA).

The vectors of the present invention may also be modified to intermediate plant transformation plasmids that contain a region of homology to an *Agrobacterium tumefaciens* vector, a T-DNA border region from *Agrobacterium tumefaciens*, and chimeric genes or expression cassettes (described above). Further, the vectors of the invention may comprise a disarmed plant tumor inducing plasmid of *Agrobacterium tumefaciens*.

The vector described in Example 1, and having a promoter from the RAmy3D gene, is suitable for use in a method of mature protein production in cell culture, where the RAmy3D promoter is induced by sugar depletion in cell culture medium. Other promoters may be selected for other applications, as indicated above. For example, for mature protein expression in germinating seeds, the coding sequence may be placed under the control of the rice  $\alpha$ -amylase RAmy1A promoter, which is inducible by gibberellic acid during seed germination.

#### B. Transformation of plant cells

Various methods for direct or vectored transformation of plant cells, *e.g.*, plant protoplast cells, have been described, *e.g.*, in above-cited PCT application WO 95/14099. As noted in that reference, promoters directing expression of selectable markers used for plant transformation (*e.g.*, nptII) should operate effectively in plant hosts. One such promoter is the nos promoter from native Ti plasmids (Herrera-Estrella, *et al.*, *Nature* 303:209-213 (1983). Others include the 35S and 19S promoters of cauliflower mosaic virus (Odell, *et al.*, *Nature* 313:810-812 (1985) and the 2' promoter (Velten, *et al.*, *EMBO J.* 3:2723-2730 (1984).

In one preferred embodiment, the embryo and endosperm of mature seeds are removed to exposed scutulum tissue cells. The cells may be transformed by DNA bombardment or injection, or by vectored transformation, *e.g.*, by *Agrobacterium* infection after bombarding the scuteller cells with microparticles to make them susceptible to *Agrobacterium* infection (Bidney *et al.*, *Plant Mol. Biol.* 18:301-313, 1992).

One preferred transformation follows the methods detailed generally in Sivamani, E. *et al.*, *Plant Cell Reports* 15:465 (1996); Zhang, S., *et al.*, *Plant Cell Reports* 15:465 (1996); and Li, L., *et al.*, *Plant Cell Reports* 12:250 (1993). Briefly, rice seeds are sterilized by standard methods, and callus induction from the seeds is carried out on MB media with 2,4D. During a first incubation period, callus tissue forms around the embryo of the seed. By the end of the incubation period, (*e.g.*, 14 days at 28°C) the calli are about 0.25 to 0.5 cm in diameter. Callus mass is then detached from the seed, and placed on fresh NB media, and incubated again for about 14 days at 28°C. After the second incubation period, satellite calli developed around the original "mother" callus mass. These satellite calli were slightly smaller, more compact and defined than the original tissue. It was these calli were transferred to fresh media. The "mother" calli was not transferred. The goal was to select only the strongest, most vigorous growing tissue for further culture.

Calli to be bombarded are selected from 14-day-old subcultures. The size, shape, color and density are all important in selecting calli in the optimal physiological condition for transformation. The calli should be between .8 and 1.1 mm in diameter. The calli should appear as spherical masses with a rough exterior.

Transformation is by particle bombardment, as detailed in the references cited above. After the transformation steps, the cells are typically grown under conditions that permit expression of the selectable marker gene. In a preferred embodiment, the selectable marker gene is HPH. It is preferred to culture the transformed cells under multiple rounds of selection to produce a uniformly stable transformed cell line.

#### IV. Cell Culture Production of Mature Heterologous Protein

Transgenic cells, typically callus cells, are cultured under conditions that favor plant cell growth, until the cells reach a desired cell density, then under conditions that favor expression of the mature protein under the control of the given promoter. Preferred culture conditions are described below and in Example 2. Purification of the mature protein secreted into the medium is by standard techniques known by those of skill in the art.

Production of mature AAT: In a preferred embodiment, the culture medium contains a phosphate buffer, *e.g.*, the 20 mM phosphate buffer, pH 6.8 described in Example 2, to reduce AAT degradation catalyzed by metals. Alternatively, or in addition, a metal chelating agent, such as EDTA, may be added to the medium.

Following the cell culture method described in Example 2, cell culture media was partially purified and the fraction containing AAT was analyzed by Western blot, as shown in Fig. 4. The first two lanes ("phosphate") show AAT bands both in the presence and absence of elastase (" +E" and "-E"), where the higher molecular weight bands in the presence of elastase correspond roughly to a 58-59 kdal AAT/elastase complex. Also as seen in the figure, expression was high in the absence of sucrose, but nearly undetectable in the presence of sucrose.

To ascertain the degree of glycosylation (as determined by apparent molecular weight by SDS-PAGE) the protein produced in culture was fractionated by SDS-PAGE and immunodetected with a labeled antibody raised against the C-terminal portion of AAT, as shown in Fig. 5. Lane 4 contains human AAT, and its migration position corresponds to about 52 kdal. In lane 3 is the plant-produced AAT, having an apparent molecular weight of about 49-50 kdal, indicating an extent of glycosylation of up to 60-80% of the glycosylation found in human AAT (non-glycosylated AAT has a molecular weight of 45 kdal).

Similar results are shown in the Western blots in Fig. 6. Lanes 1-3 in this figure correspond to decreasing amount (15, 10, and 5 ng) of human AAT; lane 4, to 10  $\mu$ l supernatant from a non-expressing plant cell line; lanes 5 and 6, to 10  $\mu$ l supernatant from AAT-expressing plant cell lines 11B and 27F, respectively, and lane 7, to 10  $\mu$ l supernatant from cell line 27F plus 250 ng trypsin. The upward mobility shift in lane 7 is indicative of association between trypsin and the plant-produced AAT.

The ability of plant-produced AAT to bind to elastase is demonstrated in Fig. 7, which shows the shift in molecular weight over a 30 minute binding interval for the 52 kdal human AAT (lanes 1-4) and the 49-50 kdal plant-produced AAT.

To demonstrate that the mature protein is produced in secreted form, with the desired N-terminus, a chimeric gene constructed as above, and having the coding sequence for mature  $\alpha_1$ -antitrypsin was expressed and secreted in cell culture as described in Example 2. The isolated protein was then sequenced at its N-terminal region, yielding the N-terminal sequence shown in Fig. 8. This sequence, which is identified herein as SEQ ID NO:22, has the same N-terminal residues as native mature  $\alpha_1$ -antitrypsin.

Production of mature ATIII: In a preferred embodiment, the culture medium contains a MES buffer, pH 6.8. Western blot analysis of the ATIII-protein produced, shown in lanes 4 and 6 in Fig. 9, shows a band corresponding to ATIII (lane 1) in cell lines 42 and 46, when grown in the absence (but not in the presence) of sucrose.

Production of mature BPN': In one embodiment of the invention, in which BPN' is secreted as the proBPN' form of the enzyme, the chaperon "pro" moiety of the enzyme facilitates enzyme folding and is cleaved from the enzyme, leaving the active mature form of BPN'. In another embodiment, the mature enzyme is co-expressed and co-secreted with the "pro" chaperon moiety, with conversion of the enzyme to active form occurring in presence of the free chaperon (Eder *et al.*, *Biochem.* (1993) 32:18-26; Eder *et al.*, (1993) *J. Mol. Biol.* 223:293-304). In yet another embodiment of the invention, the BPN' is secreted in inactive form at a pH that may be in the 6-8 range, with subsequent activation of the inactive form, *e.g.*, after enzyme isolation, by exposure to the "pro" chaperon moiety, *e.g.*, immobilized to a solid support.

In both of these embodiments, the culture medium is maintained at a pH of between 5 and 6, preferably about 5.5 during the period of active expression and secretion of BPN', to keep the BPN', which is normally active at alkaline pH, at a pH below optimal activity.

Codon optimization to the host plant's most frequent codons yielded a severalfold enhancement in the level of expressed heterologous protein in cell culture as shown in Fig. 11. The extent of enhancement is seen from the Western blot analysis shown in Fig. 10 for two cells lines and further substantiated in Fig. 11. Lane 2 (second from left) in Fig. 10 shows a Western blot of BPN' obtained in culture from cells transformed with a native proBPN' coding sequence. Two bands observed correspond to a lower molecular weight protein whose approximately 35 kdal molecular weight corresponds to that of proBPN'. The upper band corresponds to a somewhat higher molecular weight species, possibly glycosylated.

The first lane in the figure shows BPN' polypeptides produced in culture by plant cells transformed with the codon-optimized proBPN' sequence identified by SEQ ID NO:21. For

comparative purposes, the same volume of culture medium, adjusted for cell density, was applied in both lanes 1 and 2. As seen, the amount of BPN' enzyme produced with a codon-optimized sequence was severalfold higher than for subtilisin BPN' produced with the native coding sequence.

Further, a dark band or bands corresponding to mature peptide (molecular weight 27.5 kdal) was observed. However, it should be noted that directly above the band at 35kD is a more pronounced band which may be pro mature product yet to be cleaved into active form.

Fig. 11 compares the specific activity of BPN' codon-optimized (AP106) versus BPN' native (AP101) expression in rice callus cell culture, assayed using the chromogenic peptide substrate suc-Ala-Ala-Pro-Phe-pNA as described by DelMar, E.G. *et al.* (1979; *Anal. Biochem.* 99:316-320). As shown in Fig. 11, several of the cell lines transformed with codon-optimized chimeric genes produced levels of BPN', as evidenced by measured specific activity in culture medium, that were 2-5 times the highest levels observed for plant cells transformed with native proBPN' sequence.

In accordance with another aspect of the invention, it has been found that the transformed plant cell culture is able to express and secrete BPN' at a cell culture pH, pH 5.5, which largely inhibits self-degradation of mature, active BPN'. To assay for optimal pH conditions, the assay disclosed in DelMar, *et al.* (*supra*) is used to test the media derived from BPN' transformed cell lines under various pH conditions. Transformed rice callus cells are cultured in a MES medium under similar conditions as disclosed in Example 2, but where the pH of the medium is maintained at a selected pH between 5 and 8.0. At each pH, the total amount of expressed and secreted BPN' is determined by Western blot analysis. BPN' activity can be tested in the assay described by DelMar (*supra*).

## V. Production of Mature Heterologous Protein in Germinating Seeds

In this embodiment, monocot cells transformed as above are used to regenerate plants, seeds from the plants are harvested and then germinated, and the mature protein is isolated from the germinated seeds.

Plant regeneration from cultured protoplasts or callus tissue is carried by standard methods, *e.g.*, as described in Evans *et al.*, HANDBOOK OF PLANT CELL CULTURES Vol. 1: (MacMillan Publishing Co. New York, 1983); and Vasil I.R. (ed.), CELL CULTURE AND SOMATIC CELL GENETICS OF PLANTS, Acad. Press, Orlando, Vol. I, 1984, and Vol. III, 1986, and as described in the above-cited PCT application.

### A. Seed Germination Conditions

The transgenic seeds obtained from the regenerated plants are harvested, and prepared for germination by an initial steeping step, in which the seeds immersed in or sprayed with water to

increase the moisture content of the seed to between 35-45%. This initiates germination. Steeping typically takes place in a steep tank which is typically fitted with a conical end to allow the seed to flow freely out. The addition of compressed air to oxygenate the steeping process is an option. The temperature is controlled at approximately 22°C depending on the seed.

5 After steeping, the seeds are transferred to a germination compartment which contains air saturated with water and is under controlled temperature and air flows. The typical temperatures are between 12-25°C and germination is permitted to continue for from 3 to 7 days.

Where the heterologous protein coding gene is operably linked to a inducible promoter requiring a metabolite such as sugar or plant hormone, *e.g.*, 2 to 100  $\mu$ M gibberellic acid, this  
10 metabolite is added, removed or depleted from the steeping water medium and/or is added to the water saturated air used during germination. The seed absorbs the aqueous medium and begins to germinate, expressing the heterologous protein. The medium may then be withdrawn and the malting begun, by maintaining the seeds in a moist temperature controlled aerated environment. In this way, the seeds may begin growth prior to expression, so that the expressed product is less  
15 likely to be partially degraded or denatured during the process.

More specifically, the temperature during the imbibition or steeping phase will be maintained in the range of about 15-25°C, while the temperature during the germination will usually be about 20°C. The time for the imbibition will usually be from about 1 to 4 days, while the germination time will usually be an additional 1 to 10 days, more usually 3 to 7 days. Usually, the  
20 time for the malting does not exceed about ten days. The period for the malting can be reduced by using plant hormones during the imbibition, particularly gibberellic acid.

To achieve maximum production of recombinant protein from malting, the malting procedure may be modified to accommodate de-hulled and de-embryonated seeds, as described in above-cited PCT application WO 95/14099. In the absence of sugars from the endosperm, there is  
25 expected to be a 5 to 10 fold increase in RAmy3D promoter activity and thus expression of heterologous protein. Alternatively when embryoless half-seeds are incubated in 10 mM CaCl<sub>2</sub> and 5  $\mu$ M gibberellic acid, there is a 50 fold increase in RAmy1A promoter activity.

Production of mature HSA: Following the germination conditions as outlined above and further detailed in Example 3, supernatant was analyzed by Western blot. Western blot analysis  
30 shows production of HSA in germinating rice seeds, with seed samples taken 24, 72, and 120 hours after induction with gibberellin. HSA production was highest approximately 24 hours post-induction (lanes 3 and 4, Fig. 12). Bilirubin binding, a measure of correct folding of plant-produced HSA, is assayed according to the method presented in Example 3.

## 35 VI. Production of Mature Heterologous Protein in Maturing Seeds

In this embodiment, monocot cells transformed as above are used to regenerate plants, and seeds from the plants are allowed to mature, typically in the field, with consequent production of heterologous protein in the seeds.

5 Following seed maturation, the seeds and their heterologous proteins may be used directly, that is, without protein isolation; where for example, the heterologous protein is intended to confer a benefit on the seed as a whole, for example, to enrich the seed in the selected protein.

10 Alternatively, the seeds may be fractionated by standard methods to obtain the heterologous protein in enriched or purified form. In one general approach, the seed is first milled, then suspended in a suitable extraction medium, e.g., an aqueous or an organic solvent, to extract the protein or metabolite of interest. If desired the heterologous protein can be further fractionated and purified, using standard purification methods.

15 The following examples are provided by way of illustration only and not by way of limitation. Those of skill will readily recognize a variety of noncritical parameters which could be changed or modified to yield essentially similar results.

#### General Methods

20 Generally, the nomenclature and laboratory procedures with respect to standard recombinant DNA technology can be found in Sambrook, *et al.*, MOLECULAR CLONING - A LABORATORY MANUAL, Cold Spring Harbor Laboratory, Cold Spring Harbor, New York 1989 and in S.B. Gelvin and R.A. Schilperoot, PLANT MOLECULAR BIOLOGY, 1988. Other general references are provided throughout this document. The procedures therein are known in the art and are provided for the convenience of the reader.

25

#### Example 1

##### Construction of a Transforming Vector Containing a Codon-Optimized $\alpha_1$ -antitrypsin Sequence

###### A. Hygromycin Resistance Gene Insertion:

30 The 3 kb *Bam*HI fragment containing the 35S promoter-Hph-NOS was removed from the plasmid pMON410 (Monsanto, St. Louis, MO) and placed into an site-directed mutagenized *Bgl*II site in the pUC18 at 1463 to form the plasmid pUCH18+.

###### B. Terminator Insertion:

35 pOSg1ABK5 is a 5 kb *Bam*HI-*Kpn*I fragment from lambda clone  $\lambda$ OSg1A (Huang, N., *et al.*, (1990) *Nuc. Acids Res.* 18:7007) cloned into pBluescript KS- (Stratagene, San Diego, CA).



Plasmid pOSg1ABK5 was digested with *MspI* and blunted with T4 DNA polymerase followed by *SpeI* digestion. The 350 bp terminator fragment was subcloned into pUC19 (New England BioLabs, Beverly, MA), which had been digested with *BamHI*, blunted with T4 DNA polymerase and digested with *XbaI*, to form pUC19/terminator.

5

C. RAmy3D Promoter Insertion:

A 1.1 kb *NheI-PstI* fragment derived from p1AS1.5 (Huang, N. *et al.* (1993) Plant Mol. Biol. 23:737-747), was cloned into the vector pGEM5zf- [multiple cloning site (MCS) (Promega, Madison, WI): *ApaI*, *AatII*, *SphI*, *NcoI*, *SstII*, *EcoRV*, *SpeI*, *NotI*, *PstI*, *SalI*, *NdeI*, *SacI*, *MluI*, *NsiI*] at the *SpeI* and *PstI* sites to form pGEM5zf-(3D/*NheI-PstI*). pGEM5zf-(3D/*NheI-PstI*) was then digested with *PstI* and *SacI*, and two non-kinased 30mers having the complementary sequences 5' GCTTG ACCTG TAACT CGGGC CAGGC GAGCT 3' (SEQ ID NO:23) and 5' CGCCT AGCCC GAGTT ACAGG TCAAG CAGCT 3' (SEQ ID NO:24) were ligated in to form p3DProSig. The promoter fragment prepared by digesting p3DProSig with *NcoI*, blunting with T4 DNA polymerase, and digesting with *SstI* was subcloned into pUC19/terminator which had been digested with *EcoRI*, blunted with T4 DNA polymerase and digested with *SstI*, to form p3DProSigEND.

10

15

25

D. Multiple Cloning Site Insertion:

p3DProSigEND was digested with *SstI* and *SmaI* followed by the ligation of a new synthetic linker fragment constructed with the non-kinased complementary oligonucleotides 5' AGCTC CATGG CCGTG GCTCG AGTCT AGACG CGTCC CC 3' (SEQ ID NO:25) and 5' GGGGA CGCGT CTAGA CTCGA GCCAC GGCCA TGG 3' (SEQ ID NO:26) to form p3DProSigENDlink.

20

E. p3DProSigENDlink Flanking Site Modification:

p3DProSigENDlink was digested with *SalI* and blunted with T4 DNA polymerase followed by *EcoRV* digestion. The blunt fragment was then inserted into pBluescript KS+ (Stratagene) in the *EcoRV* site so that the *HindIII* site is proximal to the promoter and the *EcoRI* is proximal to the terminator sequence. The *HindIII-EcoRI* fragment was then moved into the polylinker of pUCH18+ to form the p3Dv1.0 expression vector.

30

F. RAmy1A Promoter Insertion:

A 1.9 kb *NheI-PstI* fragment derived from subclone pOSG2CA2.3 from lambda clone  $\lambda$ OSg2 (Huang *et al.* (1990) Plant Mol. Biol. 14:655-668), was cloned into the vector pGEM5zf- at

35

the *SpeI* and *PstI* sites to form pGEM5zf-(1A/*NheI-PstI*). pGEM5zf-(1A/*NheI-PstI*) was digested with *PstI* and *SacI* and two non-kinased 35mers and four kinased 32mers were ligated in, with the complementary sequences as follows: 5' GCATG CAGGT GCTGA ACACC ATGGT GAACA AACAC 3' (SEQ ID NO:27); 5' TTCTT GTCCC TTTCG GTCCT CATCG TCCTC CT 3' (SEQ ID NO:28); 5' TGGCC TCTCC TCCAA CTTGA CAGCC GGGAG CT 3' (SEQ ID O:29); 5' TTCAC CATGG TGTTC AGCAC CTGCA TGCTG CA 3' (SEQ ID NO:30); 5' CGATG AGGAC CGAAA GGGAC AAGAA GTGTT TG 3' (SEQ ID NO:31); 5' CCCGG CTGTC AAGTT GGAGG AGAGG CCAAG GAGGA 3' (SEQ ID NO:32) to form p1AProSig. The *HindIII-SacI* 0.8 kb promoter fragment was subcloned from p1AProSig into the p3Dv1.0 vector digested with *HindIII-SacI* to yield the p1Av1.0 expression vector.

#### G. Construction of p3D-AAT Plasmid

Two PCR primers were used to amplify a fragment encoding AAT according to the sequence disclosed as Genbank Accession No. K01396: N-terminal primer 5' GAGGA TCCCC AGGGA GATGC TGCCC AGAA 3' (SEQ ID NO:33) and C-terminal primer 5' CGCGC TCGAG TTATT TTTGG GTGGG ATTCA CCAC 3' (SEQ ID NO:34). The N-terminal primer amplifies to a blunt site for in-frame insertion with the end of the p3D signal peptide and the C-terminal primer contains a *XhoI* site for cloning the fragment into the vector as shown in Figs. 3A and 3B. Alternatively, the sequence encoding mature AAT (SEQ ID NO:8) or codon-optimized AAT may be chemically synthesized using techniques known in the art, incorporating a *XhoI* restriction site 3' of the termination codon for insertion into the expression vector as described above.

### Example 2

#### Production of mature $\alpha$ -antitrypsin in cell culture

After selection of transgenic callus, callus cells were suspended in liquid culture containing AA2 media (Thompson, J.A., *et al.*, *Plant Science* 47:123 (1986), at 3% sucrose, pH 5.8. Thereafter, the cells were shifted to phosphate-buffered media (20 mM phosphate buffer, pH 6.8) using 10 mL multi-well tissue culture plates and shaken at 120 rpm in the dark for 48 hours. The supernatant was then removed and stored at -80°C prior to western blot analysis.

Supernatants were concentrated using Centricon-10 filters (Amicon cat. #4207) and washed with induction media to remove substances interfering with electrophoretic migration. Samples were concentrated approximately 10 fold, and mature AAT was purified by SDS PAGE electrophoresis. The purified protein was extracted from the electrophoresis medium, and sequenced at its N-terminus, giving the sequence shown in Fig. 8, identified herein as SEQ ID NO:22.

### Example 3

#### HSA Induction in Germinating Seeds

5 After selection of transgenic plants which tested positive for the presence of a codon-optimized HSA gene driven by the GA<sub>3</sub>-responsive RAmy1A promoter, seeds were harvested and imbibed for 24 hours with 100 rpm orbital shaking in the dark at 25°C. GA<sub>3</sub> was added to a final concentration of 5 μM and incubated for an additional 24-120 hours. Total soluble protein was isolated by double grinding each seed in 120 μl grinding buffer and centrifuging at 23,000 x g for 10 minute at 4°C. The clear supernatant was carefully removed from the pellet and transferred to a fresh tube.

#### Bilirubin binding assay

Bilirubin binding to its high-affinity site on mature HSA is assayed using the method described by Jacobsen, J. *et al.* (1974; Clin. Chem. 20:783) and Reed, R.G. *et al.* (1975; 15 Biochemistry 14:4578-4583). Briefly, the concentration of free bilirubin in equilibrium with protein-bound bilirubin is determined by the rate of peroxide-peroxidase catalyzed oxidation of free bilirubin. Stock solutions of bilirubin (Nutritional Biochemicals Corp.) are prepared fresh daily in 5 mM NaOH containing 1mM EDTA and the concentration determined using a molar absorptivity of 47,500 M<sup>-1</sup> cm<sup>-1</sup> at 440 nm. An aliquot containing between 5 and 30 nmol bilirubin is added to a 20 1 cm cuvette containing 1 ml PBS and approximately 30 nmol HSA at 37°C. An absorbance spectrum between 500 and 350 nm is recorded. Aliquots of horseradish peroxidase (Sigma), 0.05 mg/ml in PBS, and 0.05% ethyl hydrogen peroxide (Ferrosan; Malmö Sweden) are added and the change in absorbance at λ<sub>max</sub> is recorded for 3-5 minutes. The concentrations of free and bound bilirubin calculated from the oxidation rate observed using varying concentrations of total bilirubin 25 are used to construct a Scatchard plot from which the association constant for a single binding site is determined.

Although the invention has been described with reference to particular embodiments, it will be appreciated that a variety of changes and modifications can be made without departing from the invention.

30

35

SEQUENCE LISTING

- 5 (1) GENERAL INFORMATION
- (i) APPLICANT: Applied Phytologics, Inc.
- 10 (ii) TITLE OF THE INVENTION: Production of Mature Proteins  
in Plants
- (iii) NUMBER OF SEQUENCES: 34
- (iv) CORRESPONDENCE ADDRESS:
- 15 (A) ADDRESSEE: Dehlinger & Associates  
(B) STREET: P.O. Box 60850  
(C) CITY: Palo Alto  
(D) STATE: CA  
(E) COUNTRY: USA  
20 (F) ZIP: 94306
- (v) COMPUTER READABLE FORM:
- (A) MEDIUM TYPE: Diskette  
(B) COMPUTER: IBM Compatible  
25 (C) OPERATING SYSTEM: DOS  
(D) SOFTWARE: FastSEQ for Windows Version 2.0
- (vi) CURRENT APPLICATION DATA:
- 30 (A) APPLICATION NUMBER: PCT/US98/03068  
(B) FILING DATE: 13-FEB-1998  
(C) CLASSIFICATION:
- (vii) PRIOR APPLICATION DATA:
- 35 (A) APPLICATION NUMBER: 60/038,169  
(B) FILING DATE: 13-FEB-1997
- (A) APPLICATION NUMBER: 60/037,991  
(B) FILING DATE: 13-FEB-1997
- 40 (A) APPLICATION NUMBER: 60/038,170  
(B) FILING DATE: 13-FEB-1997
- (A) APPLICATION NUMBER: 60/038,168  
(B) FILING DATE: 13-FEB-1997
- 45 (viii) ATTORNEY/AGENT INFORMATION:
- (A) NAME: Petithory, Joanne R  
(B) REGISTRATION NUMBER: P42,995  
(C) REFERENCE/DOCKET NUMBER: 0665-0007.41
- 50 (ix) TELECOMMUNICATION INFORMATION:
- (A) TELEPHONE: 650-324-0880  
(B) TELEFAX: 650-324-0960
- 55 (2) INFORMATION FOR SEQ ID NO:1:
- (i) SEQUENCE CHARACTERISTICS:
- 60 (A) LENGTH: 25 amino acids  
(B) TYPE: amino acid  
(D) TOPOLOGY: linear
- (ii) MOLECULE TYPE: peptide
- (vii) IMMEDIATE SOURCE:
- 65 (B) CLONE: 3D signal peptide sequence
- (xi) SEQUENCE DESCRIPTION: SEQ ID NO:1:

Met Lys Asn Thr Ser Ser Leu Cys Leu Leu Leu Val Val Leu Cys  
 1 5 10 15  
 Ser Leu Thr Cys Asn Ser Gly Gln Ala  
 20 25

5

(2) INFORMATION FOR SEQ ID NO:2:

(i) SEQUENCE CHARACTERISTICS:

- (A) LENGTH: 75 base pairs
- (B) TYPE: nucleic acid
- (C) STRANDEDNESS: single
- (D) TOPOLOGY: linear

10

(vii) IMMEDIATE SOURCE:

- (B) CLONE: native 3D signal peptide DNA sequence

15

(xi) SEQUENCE DESCRIPTION: SEQ ID NO:2:

ATGAAGAACA CCAGCAGCTT GTGTTTGCTG CTCCTCGTGG TGCTCTGCAG CTTGACCTGT 60  
 AACTCGGGCC AGGCG 75

20

(2) INFORMATION FOR SEQ ID NO:3:

(i) SEQUENCE CHARACTERISTICS:

- (A) LENGTH: 75 base pairs
- (B) TYPE: nucleic acid
- (C) STRANDEDNESS: single
- (D) TOPOLOGY: linear

25

(vii) IMMEDIATE SOURCE:

- (B) CLONE: codon-optimized 3D signal peptide DNA sequence

30

(xi) SEQUENCE DESCRIPTION: SEQ ID NO:3:

ATGAAGAACA CCTCCTCCCT CTGCCTCTG CTGCTCGTGG TCCTCTGCTC CCTGACCTGC 60  
 AACAGCGGCC AGGCC 75

35

(2) INFORMATION FOR SEQ ID NO:4:

(i) SEQUENCE CHARACTERISTICS:

- (A) LENGTH: 25 amino acids
- (B) TYPE: amino acid
- (D) TOPOLOGY: linear

40

(ii) MOLECULE TYPE: peptide

(vii) IMMEDIATE SOURCE:

- (B) CLONE: RAm1A signal peptide

45

(xi) SEQUENCE DESCRIPTION: SEQ ID NO:4:

Met Val Asn Lys His Phe Leu Ser Leu Ser Val Leu Ile Val Leu Leu  
 1 5 10 15  
 Gly Leu Ser Ser Asn Leu Thr Ala Gly  
 20 25

50

(2) INFORMATION FOR SEQ ID NO:5:

(i) SEQUENCE CHARACTERISTICS:

- (A) LENGTH: 51 base pairs
- (B) TYPE: nucleic acid
- (C) STRANDEDNESS: single
- (D) TOPOLOGY: linear

60

(vii) IMMEDIATE SOURCE:

- (B) CLONE: RAm1A 5' untranslated region (UTR)

65

(xi) SEQUENCE DESCRIPTION: SEQ ID NO:5:

## (2) INFORMATION FOR SEQ ID NO:6:

5

## (i) SEQUENCE CHARACTERISTICS:

- (A) LENGTH: 321 base pairs  
 (B) TYPE: nucleic acid  
 (C) STRANDEDNESS: single  
 (D) TOPOLOGY: linear

10

## (vii) IMMEDIATE SOURCE:

- (B) CLONE: RAmY 1A 3' untranslated region (UTR)

## (xi) SEQUENCE DESCRIPTION: SEQ ID NO:6:

15

```

GCGCACGATG ACGAGACTCT CAGTTTAGCA GATTTAACCT GCGATTTTTA CCCTGACCGG      60
TATACGTATA TACGTGCCGG CAACGAGCTG TATCCGATCC GAATTACGGA TGCAATTGTC      120
CACGAAGTAC TTCCTCCGTA AATAAAGTAG GATCAGGGAC ATACATTGT ATGGTTTTAC      180
GAATAATGCT ATGCAATAAA ATTTGCACTG CTTAATGCTT ATGCATTTTT GCTTGGTTTCG      240
ATTGTACTGG TGAATTATTG TTACTGTTCT TTTTACTTCT CGAGTGGCAG TATTGTTCTT      300
CTACGAAAAT TTGATGCGTA G                                             321
  
```

## (2) INFORMATION FOR SEQ ID NO:7:

25

## (i) SEQUENCE CHARACTERISTICS:

- (A) LENGTH: 394 amino acids  
 (B) TYPE: amino acid  
 (D) TOPOLOGY: linear

30

## (ii) MOLECULE TYPE: protein

## (vii) IMMEDIATE SOURCE:

- (B) CLONE: mature AAT amino acid sequence

## (xi) SEQUENCE DESCRIPTION: SEQ ID NO:7:

35

```

Glu Asp Pro Gln Gly Asp Ala Ala Gln Lys Thr Asp Thr Ser His His
 1          5          10          15
Asp Gln Asp His Pro Thr Phe Asn Lys Ile Thr Pro Asn Leu Ala Glu
 20          25          30
Phe Ala Phe Ser Leu Tyr Arg Gln Leu Ala His Gln Ser Asn Ser Thr
 35          40          45          50
Asn Ile Phe Phe Ser Pro Val Ser Ile Ala Thr Ala Phe Ala Met Leu
 55          60          65          70          75          80
Ser Leu Gly Thr Lys Ala Asp Thr His Asp Glu Ile Leu Glu Gly Leu
 85          90          95          100          105          110
Asn Phe Asn Leu Thr Glu Ile Pro Glu Ala Gln Ile His Glu Gly Phe
 115          120          125          130          135          140
Gln Glu Leu Leu Arg Thr Leu Asn Gln Pro Asp Ser Gln Leu Gln Leu
 145          150          155          160          165          170          175
Thr Thr Gly Asn Gly Leu Phe Leu Ser Glu Gly Leu Lys Leu Val Asp
 180          185          190          195          200          205
Lys Phe Leu Glu Asp Val Lys Lys Leu Tyr His Ser Glu Ala Phe Thr
 210          215          220          225          230          235          240
Val Asn Phe Gly Asp Thr Glu Glu Ala Lys Lys Gln Ile Asn Asp Tyr
 245          250          255
Val Glu Lys Gly Thr Gln Gly Lys Ile Val Asp Leu Val Lys Glu Leu
 260          265          270          275          280          285          290
Asp Arg Asp Thr Val Phe Ala Leu Val Asn Tyr Ile Phe Phe Lys Gly
 295          300          305          310          315          320          325
Lys Trp Glu Arg Pro Phe Glu Val Lys Asp Thr Glu Glu Asp Phe
 330          335          340          345          350          355          360
His Val Asp Gln Val Thr Thr Val Lys Val Pro Met Met Lys Arg Leu
 365          370          375          380          385          390          394
Gly Met Phe Asn Ile Gln His Cys Lys Lys Leu Ser Ser Trp Val Leu
 395          400          405          410          415          420          425
Leu Met Lys Tyr Leu Gly Asn Ala Thr Ala Ile Phe Phe Leu Pro Asp
 425          430          435          440          445          450          455
  
```

Glu Gly Lys Leu Gln His Leu Glu Asn Glu Leu Thr His Asp Ile Ile  
 260 265 270  
 Thr Lys Phe Leu Glu Asn Glu Asp Arg Arg Ser Ala Ser Leu His Leu  
 275 280 285  
 5 Pro Lys Leu Ser Ile Thr Gly Thr Tyr Asp Leu Lys Ser Val Leu Gly  
 290 295 300  
 Gln Leu Gly Ile Thr Lys Val Phe Ser Asn Gly Ala Asp Leu Ser Gly  
 305 310 315 320  
 10 Val Thr Glu Glu Ala Pro Leu Lys Leu Ser Lys Ala Val His Lys Ala  
 325 330 335  
 Val Leu Thr Ile Asp Glu Lys Gly Thr Glu Ala Ala Gly Ala Met Phe  
 340 345 350  
 Leu Glu Ala Ile Pro Met Ser Ile Pro Pro Glu Val Lys Phe Asn Lys  
 355 360 365  
 15 Pro Phe Val Phe Leu Met Ile Glu Gln Asn Thr Lys Ser Pro Leu Phe  
 370 375 380  
 Met Gly Lys Val Val Asn Pro Thr Gln Lys  
 385 390

20 (2) INFORMATION FOR SEQ ID NO:8:

(i) SEQUENCE CHARACTERISTICS:

(A) LENGTH: 1185 base pairs  
 (B) TYPE: nucleic acid  
 25 (C) STRANDEDNESS: single  
 (D) TOPOLOGY: linear

(vii) IMMEDIATE SOURCE:

30 (B) CLONE: native coding sequence of mature AAT

(xi) SEQUENCE DESCRIPTION: SEQ ID NO:8:

GAGGATCCCC AGGGAGATGC TGCCGAGAAG ACAGATACAT CCCACCATGA TCAGGATCAC 60  
 CCAACCTTCA ACAAGATCAC CCCAACCTG GCTGAGTTCG CCTTCAGCCT ATACCGCCAG 120  
 35 CTGGCACACC AGTCCAACAG CACCAATATC TTCTTCTCCC CAGTGAGCAT CGCTACAGCC 180  
 TTTGCAATGC TCTCCCTGGG GACCAAGGCT GACTCTCACG ATGAAATCCT GGAGGGCCTG 240  
 AATTTCAACC TCACGGAGAT TCCGGAGGCT CAGATCCATG AAGGCTTCCA GGAACCTCCTC 300  
 CGTACCCTCA ACCAGCCAGA CAGCCAGCTC CAGCTGACCA CCGGCAATGG CCTGTTCCCTC 360  
 AGCGAGGGCC TGAAGCTAGT GGATAAGTTT TTGGAGGATG TTAAAAAGTT GTACCACTCA 420  
 40 GAAGCCTTCA CTGTCAACTT CGGGGACACC GAAGAGGCCA AGAAACAGAT CAACGATTAC 480  
 GTGGAGAAGG GTACTCAAGG GAAAATTGTG GATTTGGTCA AGGAGCTTGA CAGAGACACA 540  
 GTTTTTGCTC TGGTGAATTA CATCTTCTTT AAAGGCAAAT GGGAGAGACC CTTTGAAGTC 600  
 AAGGACACCG AGGAAGAGGA CTTCCACGTG GACCAGGTGA CCACCGTGAA GGTGCCTATG 660  
 ATGAAGCGTT TAGGCATGTT TAACATCCAG CACTGTAAGA AGCTGTCCAG CTGGGTGCTG 720  
 45 CTGATGAAAT ACCTGGGCAA TGCCACCGCC ATCTTCTTCC TGCCTGATGA GGGGAAACTA 780  
 CAGCACCTGG AAAATGAACT CACCCACGAT ATCATCACCA AGTTCCTGGA AAATGAAGAC 840  
 AGAAGGTCTG CCAGCTTACA TTTACCCAAA CTGTCCATTA CTGGAACCTA TGATCTGAAG 900  
 AGCGTCCTGG GTCAACTGGG CATCACTAAG GTCTTCAGCA ATGGGGCTGA CCTCTCCGGG 960  
 GTCACAGAGG AGGCACCCCT GAAGCTCTCC AAGGCCGTGC ATAAGGCTGT GCTGACCATC 1020  
 50 GACGAGAAAG GACTGAAGC TGCTGGGGCC ATGTTTTTAG AGGCCATACC CATGTCTATC 1080  
 CCCCCGAGG TCAAGTTCAA CAAACCCTTT GTCTTCTTAA TGATTGAACA AAATACCAAG 1140  
 TCTCCCTCT TCATGGGAAA AGTGGTGAAT CCCACCCAAA AATAA 1185

(2) INFORMATION FOR SEQ ID NO:9:

55 (i) SEQUENCE CHARACTERISTICS:  
 (A) LENGTH: 432 amino acids  
 (B) TYPE: amino acid  
 (D) TOPOLOGY: linear

60 (ii) MOLECULE TYPE: protein

(vii) IMMEDIATE SOURCE:

(B) CLONE: mature ATIII aa sequence

65 (xi) SEQUENCE DESCRIPTION: SEQ ID NO:9:

His Gly Ser Pro Val Asp Ile Cys Thr Ala Lys Pro Arg Asp Ile Pro

	1		5		10		15									
	Met	Asn	Pro	Met	Cys	Ile	Tyr	Arg	Ser	Pro	Glu	Lys	Lys	Ala	Thr	Glu
			20						25					30		
5	Asp	Glu	Gly	Ser	Glu	Gln	Lys	Ile	Pro	Glu	Ala	Thr	Asn	Arg	Arg	Val
			35					40					45			
	Trp	Glu	Leu	Ser	Lys	Ala	Asn	Ser	Arg	Phe	Ala	Thr	Thr	Phe	Tyr	Gln
		50					55					60				
	His	Leu	Ala	Asp	Ser	Lys	Asn	Asp	Asn	Asp	Asn	Ile	Phe	Leu	Ser	Pro
10	65				70					75					80	
	Leu	Ser	Ile	Ser	Thr	Ala	Phe	Ala	Met	Thr	Lys	Leu	Gly	Ala	Cys	Asn
				85						90					95	
	Asp	Thr	Leu	Gln	Gln	Leu	Met	Glu	Val	Phe	Lys	Phe	Asp	Thr	Ile	Ser
			100						105					110		
15	Glu	Lys	Thr	Ser	Asp	Gln	Ile	His	Phe	Phe	Phe	Ala	Lys	Leu	Asn	Cys
			115					120					125			
	Arg	Leu	Tyr	Arg	Lys	Ala	Asn	Lys	Ser	Ser	Lys	Leu	Val	Ser	Ala	Asn
		130					135					140				
	Arg	Leu	Phe	Gly	Asp	Lys	Ser	Leu	Thr	Phe	Asn	Glu	Thr	Tyr	Gln	Asp
20	145				150						155					160
	Ile	Ser	Glu	Leu	Val	Tyr	Gly	Ala	Lys	Leu	Gln	Pro	Leu	Asp	Phe	Lys
				165						170					175	
	Glu	Asn	Ala	Glu	Gln	Ser	Arg	Ala	Ala	Ile	Asn	Lys	Trp	Val	Ser	Asn
			180						185					190		
25	Lys	Thr	Glu	Gly	Arg	Ile	Thr	Asp	Val	Ile	Pro	Ser	Glu	Ala	Ile	Asn
			195				200						205			
	Glu	Leu	Thr	Val	Leu	Val	Leu	Val	Asn	Thr	Ile	Tyr	Phe	Lys	Gly	Leu
		210				215						220				
	Trp	Lys	Ser	Lys	Phe	Ser	Pro	Glu	Asn	Thr	Arg	Lys	Glu	Leu	Phe	Tyr
30	225				230						235					240
	Lys	Ala	Asp	Gly	Glu	Ser	Cys	Ser	Ala	Ser	Met	Met	Tyr	Gln	Glu	Gly
				245						250					255	
	Lys	Phe	Arg	Tyr	Arg	Arg	Val	Ala	Glu	Gly	Thr	Gln	Val	Leu	Glu	Leu
			260						265					270		
35	Pro	Phe	Lys	Gly	Asp	Asp	Ile	Thr	Met	Val	Leu	Ile	Leu	Pro	Lys	Pro
			275					280					285			
	Glu	Lys	Ser	Leu	Ala	Lys	Val	Glu	Lys	Glu	Leu	Thr	Pro	Glu	Val	Leu
			290			295						300				
	Gln	Glu	Trp	Leu	Asp	Glu	Leu	Glu	Glu	Met	Met	Leu	Val	Val	His	Met
40	305				310						315					320
	Pro	Arg	Phe	Arg	Ile	Glu	Asp	Gly	Phe	Ser	Leu	Lys	Glu	Gln	Leu	Gln
				325						330					335	
	Asp	Met	Gly	Leu	Val	Asp	Leu	Phe	Ser	Pro	Glu	Lys	Ser	Lys	Leu	Pro
			340					345						350		
45	Gly	Ile	Val	Ala	Glu	Gly	Arg	Asp	Asp	Leu	Tyr	Val	Ser	Asp	Ala	Phe
			355				360						365			
	His	Lys	Ala	Phe	Leu	Glu	Val	Asn	Glu	Glu	Gly	Ser	Glu	Ala	Ala	Ala
			370				375					380				
	Ser	Thr	Ala	Val	Val	Ile	Ala	Gly	Arg	Ser	Leu	Asn	Pro	Asn	Arg	Val
50	385				390							395				400
	Thr	Phe	Lys	Ala	Asn	Arg	Pro	Phe	Leu	Val	Phe	Ile	Arg	Glu	Val	Pro
				405						410					415	
	Leu	Asn	Thr	Ile	Ile	Phe	Met	Gly	Arg	Val	Ala	Asn	Pro	Cys	Val	Lys
				420					425					430		

(2) INFORMATION FOR SEQ ID NO:10:

(i) SEQUENCE CHARACTERISTICS:

- (A) LENGTH: 1299 base pairs  
 (B) TYPE: nucleic acid  
 (C) STRANDEDNESS: single  
 (D) TOPOLOGY: linear

(vii) IMMEDIATE SOURCE:

- (B) CLONE: native ATIII DNA sequence

(xi) SEQUENCE DESCRIPTION: SEQ ID NO:10:



CACGGAAGCC CTGTGGACAT CTGCACAGCC AAGCCGCGGG ACATTCCCAT GAATCCCATG 60  
TGCATTTACC GCTCCCCGGA GAAGAAGGCA ACTGAGGATG AGGGCTCAGA ACAGAAGATC 120  
CCGGAGGCCA CCAACCGGCG TGTCTGGGAA CTGTCCAAGG CCAATTCCCG CTTTGCTACC 180  
ACTTCTATC AGCACCTGGC AGATTCCAAG AATGACAATG ATAACATTTT CCTGTCACCC 240  
5 CTGAGTATCT CCACGGCTTT TGCTATGACC AAGCTGGGTG CCTGTAATGA CACCCTCCAG 300  
CAACTGATGG AGGTATTTAA GTTTGACACC ATATCTGAGA AAACATCTGA TCAGATCCAC 360  
TTCTTCTTTG CCAAACCTGAA CTGCCGACTC TATCGAAAAG CCAACAAATC CTCCAAGTTA 420  
GTATCAGCCA ATCGCCTTTT TGGAGACAAA TCCCTTACCT TCAATGAGAC CTACCAGGAC 480  
ATCAGTGAGT TGGTATATGG AGCCAAGCTC CAGCCCCCTGG ACTTCAAGGA AAATGCAGAG 540  
10 CAATCCAGAG CGGCCATCAA CAAATGGGTG TCCAATAAGA CCGAAGGCCG AATCACCGAT 600  
GTCATTCCCT CGGAAGCCAT CAATGAGCTC ACTGTTCTGG TGCTGGTTAA CACCATTTAC 660  
TTCAAGGGCC TGTGGAAGTC AAAGTTCAGC CCTGAGAACA CAAGGAAGGA ACTGTTCTAC 720  
AAGGCTGATG GAGAGTCGTG TTCAGCATCT ATGATGTACC AGGAAGGCCAA GTTCCGTTAT 780  
CGGCGGTGG CTGAAGGCAC CCAGGTGCTT GAGTTGCCCT TCAAAGGTGA TGACATCACC 840  
15 ATGGTCTTCA TCTTGCCCAA GCCTGAGAAG AGCCTGGCCA AGGTGGAGAA GGAACCTCACC 900  
CCAGAGGTGC TGCAGGAGTG GCTGGATGAA TTGGAGGAGA TGATGCTGGT GGTTCACATG 960  
CCCCGCTTCC GCATTGAGGA CGGCTTCAGT TTGAAGGAGC AGCTGCAAGA CATGGGCCCT 1020  
GTCGATCTGT TCAGCCCTGA AAAGTCCAAA CTCCCAGGTA TTGTTGCAGA AGGCCGAGAT 1080  
GACCTCTATG TCTCAGATGC ATTCCATAAG GCATTTCTTG AGGTAAATGA AGAAGGCAT 1140  
20 GAAGCAGCTG CAAGTACCGC TGTGTGATT GCTGGCCGTT CGCTAAACCC CAACAGGGTG 1200  
ACTTTC AAG CCAACAGGCC CTTCCTGGTT TTTATAAGAG AAGTTCCTCT GAACACTATT 1260  
ATCTTCATGG GCAGAGTAGC CAACCCTTGT GTTAAGTAA 1299

(2) INFORMATION FOR SEQ ID NO:11:

25

(i) SEQUENCE CHARACTERISTICS:

- (A) LENGTH: 585 amino acids
- (B) TYPE: amino acid
- (D) TOPOLOGY: linear

30

(ii) MOLECULE TYPE: protein

(vii) IMMEDIATE SOURCE:

- (B) CLONE: mature HSA amino acid sequence

35

(xi) SEQUENCE DESCRIPTION: SEQ ID NO:11:

Asp Ala His Lys Ser Glu Val Ala His Arg Phe Lys Asp Leu Gly Glu  
1 5 10 15  
40 Glu Asn Phe Lys Ala Leu Val Leu Ile Ala Phe Ala Gln Tyr Leu Gln  
20 25 30  
Gln Cys Pro Phe Glu Asp His Val Lys Leu Val Asn Glu Val Thr Glu  
35 40 45  
Phe Ala Lys Thr Cys Val Ala Asp Glu Ser Ala Glu Asn Cys Asp Lys  
50 55 60  
45 Ser Leu His Thr Leu Phe Gly Asp Lys Leu Cys Thr Val Ala Thr Leu  
65 70 75 80  
Arg Glu Thr Tyr Gly Glu Met Ala Asp Cys Cys Ala Lys Gln Glu Pro  
85 90 95  
50 Glu Arg Asn Glu Cys Phe Leu Gln His Lys Asp Asp Asn Pro Asn Leu  
100 105 110  
Pro Arg Leu Val Arg Pro Glu Val Asp Val Met Cys Thr Ala Phe His  
115 120 125  
Asp Asn Glu Glu Thr Phe Leu Lys Lys Tyr Leu Tyr Glu Ile Ala Arg  
130 135 140  
55 Arg His Pro Tyr Phe Tyr Ala Pro Glu Leu Leu Phe Phe Ala Lys Arg  
145 150 155 160  
Tyr Lys Ala Ala Phe Thr Glu Cys Cys Gln Ala Ala Asp Lys Ala Ala  
165 170 175  
60 Cys Leu Leu Pro Lys Leu Asp Glu Leu Arg Asp Glu Gly Lys Ala Ser  
180 185 190  
Ser Ala Lys Gln Arg Leu Lys Cys Ala Ser Leu Gln Lys Phe Gly Glu  
195 200 205  
Arg Ala Phe Lys Ala Trp Ala Val Ala Arg Leu Ser Gln Arg Phe Pro  
210 215 220  
65 Lys Ala Glu Phe Ala Glu Val Ser Lys Leu Val Thr Asp Leu Thr Lys  
225 230 235 240  
Val His Thr Glu Cys Cys His Gly Asp Leu Leu Glu Cys Ala Asp Asp

					245					250					255	
	Arg	Ala	Asp	Leu	Ala	Lys	Tyr	Ile	Cys	Glu	Asn	Gln	Asp	Ser	Ile	Ser
				260					265					270		
5	Ser	Lys	Leu	Lys	Glu	Cys	Cys	Glu	Lys	Pro	Leu	Leu	Glu	Lys	Ser	His
			275					280					285			
	Cys	Ile	Ala	Glu	Val	Glu	Asn	Asp	Glu	Met	Pro	Ala	Asp	Leu	Pro	Ser
			290				295					300				
	Leu	Ala	Ala	Asp	Phe	Val	Glu	Ser	Lys	Asp	Val	Cys	Lys	Asn	Tyr	Ala
	305					310					315					320
10	Glu	Ala	Lys	Asp	Val	Phe	Leu	Gly	Met	Phe	Leu	Tyr	Glu	Tyr	Ala	Arg
				325						330					335	
	Arg	His	Pro	Asp	Tyr	Ser	Val	Val	Leu	Leu	Leu	Arg	Leu	Ala	Lys	Thr
				340					345					350		
	Tyr	Glu	Thr	Thr	Leu	Glu	Lys	Cys	Cys	Ala	Ala	Ala	Asp	Pro	His	Glu
15				355				360					365			
	Cys	Tyr	Ala	Lys	Val	Phe	Asp	Glu	Phe	Lys	Pro	Leu	Val	Glu	Glu	Pro
			370				375					380				
	Gln	Asn	Leu	Ile	Lys	Gln	Asn	Cys	Glu	Leu	Phe	Lys	Gln	Leu	Gly	Glu
	385				390						395					400
20	Tyr	Lys	Phe	Gln	Asn	Ala	Leu	Leu	Val	Arg	Tyr	Thr	Lys	Lys	Val	Pro
				405						410					415	
	Gln	Val	Ser	Thr	Pro	Thr	Leu	Val	Glu	Val	Ser	Arg	Asn	Leu	Gly	Lys
				420					425					430		
	Val	Gly	Ser	Lys	Cys	Cys	Lys	His	Pro	Glu	Ala	Lys	Arg	Met	Pro	Cys
25				435				440					445			
	Ala	Glu	Asp	Tyr	Leu	Ser	Val	Val	Leu	Asn	Gln	Leu	Cys	Val	Leu	His
				450			455					460				
	Glu	Lys	Thr	Pro	Val	Ser	Asp	Arg	Val	Thr	Lys	Cys	Cys	Thr	Glu	Ser
	465				470						475					480
30	Leu	Val	Asn	Arg	Arg	Pro	Cys	Phe	Ser	Ala	Leu	Glu	Val	Asp	Glu	Thr
				485						490					495	
	Tyr	Val	Pro	Lys	Glu	Phe	Asn	Ala	Glu	Thr	Phe	Thr	Phe	His	Ala	Asp
				500					505					510		
	Ile	Cys	Thr	Leu	Ser	Glu	Lys	Glu	Arg	Gln	Ile	Lys	Lys	Gln	Thr	Ala
35				515				520					525			
	Leu	Val	Glu	Leu	Val	Lys	His	Lys	Pro	Lys	Ala	Thr	Lys	Glu	Gln	Leu
				530			535					540				
	Lys	Ala	Val	Met	Asp	Asp	Phe	Ala	Ala	Phe	Val	Glu	Lys	Cys	Cys	Lys
	545				550					555						560
40	Ala	Asp	Asp	Lys	Glu	Thr	Cys	Phe	Ala	Glu	Glu	Gly	Lys	Lys	Leu	Val
				565						570					575	
	Ala	Ala	Ser	Gln	Ala	Ala	Leu	Gly	Leu							
				580				585								

45

(2) INFORMATION FOR SEQ ID NO:12:

- (i) SEQUENCE CHARACTERISTICS:
- (A) LENGTH: 1865 base pairs
- (B) TYPE: nucleic acid
- (C) STRANDEDNESS: single
- (D) TOPOLOGY: linear

50

(vii) IMMEDIATE SOURCE:

- (B) CLONE: native coding sequence of mature HSA

55

(xi) SEQUENCE DESCRIPTION: SEQ ID NO:12:

	AGATGCACAC	AAGAGTGAGG	TTGCTCATCG	GTTTAAAGAT	TTGGGAGAAG	AAAATTTCAA	60
	AGCCTTGGTG	TTGATTGCCT	TTGCTCAGTA	TC TTCAGCAG	TGTCCATTG	AAGATCATGT	120
60	AAAATTAGTG	AATGAAGTAA	CTGAATTTGC	AAAAACATGT	G TAGCTGATG	AGTCAGCTGA	180
	AAATTGTGAC	AAATCACTTC	ATACCCTTTT	TGGAGACAAA	TTATGCACAG	TTGCAACTCT	240
	TCGTGAAACC	TATGGTGAAA	TGGCTGACTG	CTGTGCAAAA	CAAGAACCTG	AGAGAAATGA	300
	ATGCTTCTTG	CAACACAAAG	ATGACAACCC	AAACCTCCCC	CGATTGGTGA	GACCAGAGGT	360
	TGATGTGATG	TGCACTGCTT	TTCATGACAA	TGAAGAGACA	TTTTTGAAAA	AATACTTATA	420
65	TGAAATTGCC	AGAAGACATC	CTTACTTTTA	TGCCCCGAA	CTCCTTTTCT	TTGCTAAAAG	480
	GTATAAAGCT	GCTTTTACAG	AATGTTGCCA	AGCTGCTGAT	AAAGCTGCCT	GCCTGTTGCC	540
	AAAGCTCGAT	GAACTTCGGG	ATGAAGGGAA	GGCTTCGTCT	GCCAAACAGA	GACTCAAATG	600

TGCCAGTCTC CAAAAATTG GAGAAAGAGC TTTCAAAGCA TGGGCAGTGG CTCGCCTGAG 660  
 CCAGAGATTT CCCAAAGCTG AGTTTGCAGA AGTTTCCAAG TTAGTGACAG ATCTTACCAA 720  
 AGTCCACACG GAATGCTGCC ATGGAGATCT GCTTGAATGT GCTGATGACA GGGCGGACCT 780  
 TGCCAAGTAT ATCTGTGAAA ATCAGGATTC GATCTCCAGT AAACCTGAAGG AATGCTGTGA 840  
 5 AAAACCTCTG TTGAAAAAAT CCCACTGCAT TGCCGAAGTG GAAAATGATG AGATGCCTGC 900  
 TGACTTGCCT TCATTAGCTG CTGATTTTGT TGAAGTAAG GATGTTTGCA AAAACTATGC 960  
 TGAGGCAAAG GATGTCTTCC TGGGCATGTT TTTGTATGAA TATGCAAGAA GGCATCCTGA 1020  
 TTA CTCTGTC GTGCTGCTGC TGAGACTTGC CAAGACATAT GAAACCACTC TAGAGAAGTG 1080  
 CTGTGCCGCT GCAGATCCTC ATGAATGCTA TGCCAAAGTG TTCGATGAAT TTAACCTCT 1140  
 10 TGTGGAAGAG CCTCAGAATT TAATCAAACA AAACCTGTGAG CTTTFTAAGC AGCTTGGAGA 1200  
 GTACAAATTC CAGAATGCGC TATTAGTTCG TTACACCAAG AAAGTACCCC AAGTGTCAAC 1260  
 TCCAACCTT GTAGAGGTCT CAAGAAACCT AGGAAAAGTG GGCAGCAAAT GTTGTAACA 1320  
 TCCTGAAGCA AAAAGAATGC CCTGTGCAGA AGACTATCTA TCCGTGGTCC TGAACCAATT 1380  
 ATGTGTGTTG CATGAGAAAA CGCCAGTAAG TGACAGAGTC ACAAATGCT GCACAGAGTC 1440  
 15 CTTGGTGAAC AGGCGACCAT GCTTTTCAGC TCTGGAAGTC GATGAAACAT ACGTTCCCAA 1500  
 AGAGTTTAAT GCTGAAACAT TCACCTTCCA TGAGATATA TGCACACTTT CTGAGAAGGA 1560  
 GAGACAAATC AAGAAACAAA CTGCATTGT TGAGCTTGTG AAACACAAGC CCAAGGCAAC 1620  
 AAAAGAGCAA CTGAAAGCTG TTATGGATGA TTTGCGAGCT TTTGTAGAGA AGTGCTGCAA 1680  
 GGCTGACGAT AAGGAGACCT GCTTTGCCGA GGAGGTAAA AAACCTGTTG CTGCAAGTCA 1740  
 20 AGCTGCCTTA GGCTTATAAC ATCTACATTT AAAAGCATCT CAGCCTACCA TGAGAATAAG 1800  
 AGAAAGAAA TGAAGATCAA AAGCTTATTC ATCTGTTTTT TTTTTCGTTG GTGTAAGCC 1860  
 AACAC 1865

(2) INFORMATION FOR SEQ ID NO:13:

- 25 (i) SEQUENCE CHARACTERISTICS:
- (A) LENGTH: 352 amino acids
  - (B) TYPE: amino acid
  - (D) TOPOLOGY: linear
- 30 (ii) MOLECULE TYPE: protein
- (vii) IMMEDIATE SOURCE:
- (B) CLONE: native proBPN' amino acid sequence
- 35 (xi) SEQUENCE DESCRIPTION: SEQ ID NO:13:

Ala Gly Lys Ser Asn Gly Glu Lys Lys Tyr Ile Val Gly Phe Lys Gln  
 1 5 10 15  
 Thr Met Ser Thr Met Ser Ala Ala Lys Lys Lys Asp Val Ile Ser Glu  
 20 25 30  
 40 Lys Gly Gly Lys Val Gln Lys Gln Phe Lys Tyr Val Asp Ala Ala Ser  
 35 40 45  
 Ala Thr Leu Asn Glu Lys Ala Val Lys Glu Leu Lys Lys Asp Pro Ser  
 50 55 60  
 45 Val Ala Tyr Val Glu Glu Asp His Val Ala His Ala Tyr Ala Gln Ser  
 65 70 75 80  
 Val Pro Tyr Gly Val Ser Gln Ile Lys Ala Pro Ala Leu His Ser Gln  
 85 90 95  
 50 Gly Tyr Thr Gly Ser Asn Val Lys Val Ala Val Ile Asp Ser Gly Ile  
 100 105 110  
 Asp Ser Ser His Pro Asp Leu Lys Val Ala Gly Gly Ala Ser Met Val  
 115 120 125  
 Pro Ser Glu Thr Asn Pro Phe Gln Asp Asn Asn Ser His Gly Thr His  
 130 135 140  
 55 Val Ala Gly Thr Val Ala Ala Leu Asn Asn Ser Ile Gly Val Leu Gly  
 145 150 155 160  
 Val Ala Pro Ser Ala Ser Leu Tyr Ala Val Lys Val Leu Gly Ala Asp  
 165 170 175  
 60 Gly Ser Gly Gln Tyr Ser Trp Ile Ile Asn Gly Ile Glu Trp Ala Ile  
 180 185 190  
 Ala Asn Asn Met Asp Val Ile Asn Met Ser Leu Gly Gly Pro Ser Gly  
 195 200 205  
 Ser Ala Ala Leu Lys Ala Ala Val Asp Lys Ala Val Ala Ser Gly Val  
 210 215 220  
 65 Val Val Val Ala Ala Ala Gly Asn Glu Gly Thr Ser Gly Ser Ser Ser  
 225 230 235 240  
 Thr Val Gly Tyr Pro Gly Lys Tyr Pro Ser Val Ile Ala Val Gly Ala

				245					250					255		
	Val	Asp	Ser	Ser	Asn	Gln	Arg	Ala	Ser	Phe	Ser	Ser	Val	Gly	Pro	Glu
				260					265					270		
5	Leu	Asp	Val	Met	Ala	Pro	Gly	Val	Ser	Ile	Gln	Ser	Thr	Leu	Pro	Gly
			275					280					285			
	Asn	Lys	Tyr	Gly	Ala	Tyr	Asn	Gly	Thr	Ser	Met	Ala	Ser	Pro	His	Val
		290					295					300				
	Ala	Gly	Ala	Ala	Ala	Leu	Ile	Leu	Ser	Lys	His	Pro	Asn	Trp	Thr	Asn
	305					310					315				320	
10	Thr	Gln	Val	Arg	Ser	Ser	Leu	Glu	Asn	Thr	Thr	Thr	Lys	Leu	Gly	Asp
					325					330					335	
	Ser	Phe	Tyr	Tyr	Gly	Lys	Gly	Leu	Ile	Asn	Val	Gln	Ala	Ala	Ala	Gln
				340					345					350		

15 (2) INFORMATION FOR SEQ ID NO:14:

(i) SEQUENCE CHARACTERISTICS:

- (A) LENGTH: 1056 base pairs
- (B) TYPE: nucleic acid
- (C) STRANDEDNESS: single
- (D) TOPOLOGY: linear

(vii) IMMEDIATE SOURCE:

- (B) CLONE: native proBPN' coding sequence

(xi) SEQUENCE DESCRIPTION: SEQ ID NO:14:

	GCAGGGAAAT	CAAACGGGGA	AAAGAAATAT	ATTGTCGGGT	TTAAACAGAC	AATGAGCAGC	60
	ATGAGCGCCG	CTAAGAAGAA	AGATGTCATT	TCTGAAAAAG	GCGGGAAAGT	GCAAAAAGCAA	120
30	TTCAAATATG	TAGACGCAGC	TTCAGCTACA	TTAAACGAAA	AAGCTGTAAA	AGAATTGAAA	180
	AAAGACCCGA	GCGTCGCTTA	CGTTGAAGAA	GATCACGTAG	CACATGCGTA	CGCGCAGTCC	240
	GTGCCTTACG	GCGTATCACA	AATTAAGCC	CCTGCTCTGC	ACTCTCAAGG	CTACACTGGA	300
	TCAAATGTTA	AAGTAGCGGT	TATCGACAGC	GGTATCGATT	CTTCTCATCC	TGATTTAAAG	360
	GTAGCAGGCG	GAGCCAGCAT	GGTTCCTTCT	GAAACAAATC	CTTTCCAAGA	CAACAACCTCT	420
35	CACGGAATC	ACGTTGCCGG	CACAGTTGCG	GCTCTTAATA	ACTCAATCGG	TGTATTAGGC	480
	GTTGCGCCAA	GCGCATCACT	TTACGCTGTA	AAAGTTCTCG	GTGCTGACGG	TTCCGGCCAA	540
	TACAGCTGGA	TCATTAACGG	AATCGAGTGG	GCGATCGCAA	ACAATATGGA	CGTTATTAAC	600
	ATGAGCCTCG	GCGGACCTTC	TGTTTCTGCT	GCTTTAAAAG	CGGCAGTTGA	TAAAGCCGTT	660
	GCATCCGGCG	TCGTAGTCGT	TGCGGCAGCC	GGTAACGAAG	GCACTTCCGG	CAGCTCAAGC	720
40	ACAGTGGGCT	ACCCTGGTAA	ATACCCTTCT	GTCATTGCAG	TAGGCGCTGT	TGACAGCAGC	780
	AACCAAAGAG	CATCTTTCTC	AAGCGTAGGA	CCTGAGCTTG	ATGTCATGGC	ACCTGGCGTA	840
	TCTATCCAAA	GCACGCTTCC	TGGAAACAAA	TACGGGGCGT	ACAACGGTAC	GTCATGGCA	900
	TCTCCGACG	TTGCCGGAGC	GGCTGCTTTG	ATTCTTTCTA	AGCACCCGAA	CTGGACAAAC	960
	ACTCAAGTCC	GCAGCAGTTT	AGAAAACACC	ACTACAAAAC	TTGGTGATTC	TTTCTACTAT	1020
45	GGAAAAGGGC	TGATCAACGT	ACAGGCGGCA	GCTCAG			1056

(2) INFORMATION FOR SEQ ID NO:15:

(i) SEQUENCE CHARACTERISTICS:

- (A) LENGTH: 77 amino acids
- (B) TYPE: amino acid
- (D) TOPOLOGY: linear

(ii) MOLECULE TYPE: peptide

- (vii) IMMEDIATE SOURCE:
- (B) CLONE: subtilisin BPN' pro-peptide

(xi) SEQUENCE DESCRIPTION: SEQ ID NO:15:

60	Ala	Gly	Lys	Ser	Asn	Gly	Glu	Lys	Lys	Tyr	Ile	Val	Gly	Phe	Lys	Gln
	1				5					10					15	
	Thr	Met	Ser	Thr	Met	Ser	Ala	Ala	Lys	Lys	Lys	Asp	Val	Ile	Ser	Glu
				20					25					30		
	Lys	Gly	Gly	Lys	Val	Gln	Lys	Gln	Phe	Lys	Tyr	Val	Asp	Ala	Ala	Ser
65			35					40					45			
	Ala	Thr	Leu	Asn	Glu	Lys	Ala	Val	Lys	Glu	Leu	Lys	Lys	Asp	Pro	Ser
		50					55					60				

Val Ala Tyr Val Glu Glu Asp His Val Ala His Ala Tyr  
65 70 75

5 (2) INFORMATION FOR SEQ ID NO:16:

(i) SEQUENCE CHARACTERISTICS:

(A) LENGTH: 275 amino acids  
(B) TYPE: amino acid  
10 (D) TOPOLOGY: linear

(ii) MOLECULE TYPE: protein

(vii) IMMEDIATE SOURCE:

(B) CLONE: native mature BPN' amino acid sequence  
15

(xi) SEQUENCE DESCRIPTION: SEQ ID NO:16:

Ala Gln Ser Val Pro Tyr Gly Val Ser Gln Ile Lys Ala Pro Ala Leu  
1 5 10 15  
20 His Ser Gln Gly Tyr Thr Gly Ser Asn Val Lys Val Ala Val Ile Asp  
20 25 30  
Ser Gly Ile Asp Ser Ser His Pro Asp Leu Lys Val Ala Gly Gly Ala  
35 40 45  
Ser Met Val Pro Ser Glu Thr Asn Pro Phe Gln Asp Asn Asn Ser His  
25 50 55 60  
Gly Thr His Val Ala Gly Thr Val Ala Ala Leu Asn Asn Ser Ile Gly  
65 70 75 80  
Val Leu Gly Val Ala Pro Ser Ala Ser Leu Tyr Ala Val Lys Val Leu  
85 90 95  
30 Gly Ala Asp Gly Ser Gly Gln Tyr Ser Trp Ile Ile Asn Gly Ile Glu  
100 105 110  
Trp Ala Ile Ala Asn Asn Met Asp Val Ile Asn Met Ser Leu Gly Gly  
115 120 125  
Pro Ser Gly Ser Ala Ala Leu Lys Ala Ala Val Asp Lys Ala Val Ala  
35 130 135 140  
Ser Gly Val Val Val Val Ala Ala Gly Asn Glu Gly Thr Ser Gly  
145 150 155 160  
Ser Ser Ser Thr Val Gly Tyr Pro Gly Lys Tyr Pro Ser Val Ile Ala  
165 170 175  
40 Val Gly Ala Val Asp Ser Ser Asn Gln Arg Ala Ser Phe Ser Ser Val  
180 185 190  
Gly Pro Glu Leu Asp Val Met Ala Pro Gly Val Ser Ile Gln Ser Thr  
195 200 205  
Leu Pro Gly Asn Lys Tyr Gly Ala Tyr Asn Gly Thr Ser Met Ala Ser  
45 210 215 220  
Pro His Val Ala Gly Ala Ala Ala Leu Ile Leu Ser Lys His Pro Asn  
225 230 235 240  
Trp Thr Asn Thr Gln Val Arg Ser Ser Leu Glu Asn Thr Thr Thr Lys  
245 250 255  
50 Leu Gly Asp Ser Phe Tyr Tyr Gly Lys Gly Leu Ile Asn Val Gln Ala  
260 265 270  
Ala Ala Gln  
275

55 (2) INFORMATION FOR SEQ ID NO:17:

(i) SEQUENCE CHARACTERISTICS:

(A) LENGTH: 275 amino acids  
(B) TYPE: amino acid  
60 (D) TOPOLOGY: linear

(ii) MOLECULE TYPE: protein

(vii) IMMEDIATE SOURCE:

(B) CLONE: amino acid sequence of mature BPN' variant  
65

(xi) SEQUENCE DESCRIPTION: SEQ ID NO:17:

5 Ala Gln Ser Val Pro Tyr Gly Val Ser Gln Ile Lys Ala Pro Ala Leu  
1 5 10 15  
His Ser Gln Gly Tyr Thr Gly Ser Asn Val Lys Val Ala Val Ile Asp  
20 30  
Ser Gly Ile Asp Ser Ser His Pro Asp Leu Lys Val Ala Gly Gly Ala  
35 40 45  
10 Ser Met Val Pro Ser Glu Thr Asn Pro Phe Gln Asp Thr Asn Ser His  
50 55 60  
Gly Thr His Val Ala Gly Thr Val Ala Ala Leu Thr Asn Ser Ile Gly  
65 70 75 80  
Val Leu Gly Val Ala Pro Ser Ala Ser Leu Tyr Ala Val Lys Val Leu  
85 90 95  
15 Gly Ala Asp Gly Ser Gly Gln Tyr Ser Trp Ile Ile Asn Gly Ile Glu  
100 105 110  
Trp Ala Ile Ala Asn Asn Met Asp Val Ile Thr Met Ser Leu Gly Gly  
115 120 125  
20 Pro Ser Gly Ser Ala Ala Leu Lys Ala Ala Val Asp Lys Ala Val Ala  
130 135 140  
Ser Gly Val Val Val Val Ala Ala Ala Gly Asn Glu Gly Thr Ser Gly  
145 150 155 160  
Ser Ser Ser Thr Val Gly Tyr Pro Gly Lys Tyr Pro Ser Val Ile Ala  
165 170 175  
25 Val Gly Ala Val Asp Ser Ser Asn Gln Arg Ala Ser Phe Ser Ser Val  
180 185 190  
Gly Pro Glu Leu Asp Val Met Ala Pro Gly Val Ser Ile Gln Ser Thr  
195 200 205  
30 Leu Pro Gly Asn Lys Tyr Gly Ala Tyr Ser Gly Thr Ser Met Ala Ser  
210 215 220  
Pro His Val Ala Gly Ala Ala Ala Leu Ile Leu Ser Lys His Pro Thr  
225 230 235 240  
Trp Thr Asn Thr Gln Val Arg Ser Ser Leu Glu Asn Thr Thr Thr Lys  
245 250 255  
35 Leu Gly Asp Ser Phe Tyr Tyr Gly Lys Gly Leu Ile Asn Val Gln Ala  
260 265 270  
Ala Ala Gln  
275  
40

(2) INFORMATION FOR SEQ ID NO:18:

(i) SEQUENCE CHARACTERISTICS:

- 45 (A) LENGTH: 1260 base pairs  
(B) TYPE: nucleic acid  
(C) STRANDEDNESS: single  
(D) TOPOLOGY: linear

(vii) IMMEDIATE SOURCE:

- 50 (B) CLONE: codon-optimized 3D signal peptide-AAT DNA sequence

(xi) SEQUENCE DESCRIPTION: SEQ ID NO:18:

55 ATGAAGAACA CCTCCTCCCT CTGCCTCCTG CTGCTCGTGG TCCTCTGCTC CCTGACCTGC 60  
AACAGCGGCC AGGCCGAGGA CCCGCAGGGC GACGCCGCC AGAAGACCGA CACCAGCCAC 120  
CACGACCAGG ACCACCCGAC GTTCAACAAG ATCACCCCGA ATTTGGCCGA ATTCGCCTTC 180  
AGCCTGTACC GCCAGCTCGC GCACCAAGTCC AACTCCACCA ACATCTTCTT CAGCCCGGTG 240  
AGCATCGCCA CCGCCTTCGC CATGCTGTCC CTGGGTACCA AGGCGGACAC CCACGACGAG 300  
ATCCTCGAAG GGCTGAACTT CAACCTGACG GAGATCCCGG AGGCGCAGAT CCACGAGGGC 360  
60 TTCCAGGAGC TGCTCAGGAC GCTCAACCAG CCGGACTCCC AGCTCCAGCT CACCACCGGC 420  
AACGGGCTCT TCCTGTCCGA GGGCCTCAAG CTCGTCGATA AGTTCCTGGA GGACGTGAAG 480  
AAGTCTACC ACTCCGAGGC GTTCACCGTC AACTTCGGGG ACACCGAGGA GGCCAAGAAG 540  
CAGATCAACG ACTACGTCTGA GAAGGGGACC CAGGGCAAGA TCGTGGACCT GGTC AAGGAA 600  
TTGGACAGGG ACACCGTCTT CGCGCTCGTC AACTACATCT TCTTCAAGGG CAAGTGGGAG 660  
65 CGCCCGTTCG AGGTGAAGGA CACCGAGGAG GAGGACTTCC ACGTCGACCA GTCACCACC 720  
GTCAAGTCC CGATGATGAA GAGGCTCGGC ATGTTCAACA TCCAGCACTG CAAGAAGCTC 780  
TCCAGCTGGG TGCTCCTCAT GAAGTACCTG GGAACGCCA CCGCATCTT CTTCCTGCCG 840

GACGAGGGCA AGCTCCAGCA CCTGGAGAAC GAGCTGACGC ACGACATCAT CACGAAGTTC 900  
 CTGGAGAACG AGGACAGGCG CTCCGCTAGC CTCCACCTCC CGAAGCTGAG CATCACCGGC 960  
 ACGTACGACC TGAAGAGCGT GCTGGGCCAG CTGGGCATCA CGAAGGTCTT CAGCAACGGC 1020  
 GCGGACCTCT CCGGCGTGAC GGAGGAGGCC CCCCTGAAGC TCTCCAAGGC CGTGCACAAG 1080  
 5 GCGGTGCTCA CGATCGACGA GAAGGGGACG GAAGCTGCCG GGGCCATGTT CCTGGAGGCC 1140  
 ATCCCCATGT CCATCCCGCC CGAGGTCAAG TTCAACAAGC CCTTCGTCTT CCTGATGATC 1200  
 GAGCAGAACA CGAAGAGCCC CCTCTTCATG GGAAGGTCCG TCAACCCAC GCAGAAGTGA 1260

(2) INFORMATION FOR SEQ ID NO:19:

10

(i) SEQUENCE CHARACTERISTICS:

- (A) LENGTH: 1382 base pairs
- (B) TYPE: nucleic acid
- (C) STRANDEDNESS: single
- (D) TOPOLOGY: linear

15

(vii) IMMEDIATE SOURCE:

- (B) CLONE: codon-optimized 3D signal peptide-ATIII DNA sequen

20

(xi) SEQUENCE DESCRIPTION: SEQ ID NO:19:

ATGAAGAACA CCTCCTCCCT CTGCCTCCTG CTGCTCGTGG TCCTCTGCTC CCTGACCTGC 60  
 AACAGCGGCC AGGCCACGG AAGCCCTGTG GACATCTGCA CAGCCAAGCC GCGGGACATT 120  
 CCCATGAATC CCATGTGCAT TTACCGCTCC CCGGAGAAGA AGGCAACTGA GGATGAGGGC 180  
 25 TCAGAACAGA AGATCCCGGA GGCCACCAAC CGGCGTGTCT GGGAACTGTC CAAGGCCAAT 240  
 TCCCCGTTTG CTACCACTTT CTATCAGCAC CTGGCAGATT CCAAGAATGA CAATGATAAC 300  
 ATTTTCCTGT CACCCCTGAG TATCTCCACG GCTTTTGCTA TGACCAAGCT GGGTGCCTGT 360  
 AATGACACCC TCCAGCAACT GATGGAGGTA TTTAAGTTTG ACACCATATC TGAGAAAACA 420  
 TCTGATCAGA TCCACTTCTT CTTTGCCAAA CTGAACTGCC GACTCTATCG AAAAGCCAAC 480  
 30 AAATCCTCCA AGTTAGTATC AGCCAATCGC CTTTTTGGAG ACAAATCCCT TACCTTCAAT 540  
 GAGACCTACC AGGACATCAG TGAGTTGGTA TATGGAGCCA AGCTCCAGCC CCTGGACTTC 600  
 AAGGAAAATG CAGAGCAATC CAGAGCGGCC ATCAACAAAT GGGTGTCCAA TAAGACCGAA 660  
 GGCCGAATCA CCGATGTCAT TCCCTCGGAA GCCATCAATG AGCTCACTGT TCTGGTGCTG 720  
 GTTAACACCA TTTACTTCAA GGGCCTGTGG AAGTCAAAGT TCAGCCCTGA GAACACAAGG 780  
 35 AAGGAACGTG TCTACAAGGC TGATGGAGAG TCGTGTTTCA CATCTATGAT GTACCAGGAA 840  
 GGCAAGTTCC GTTATCGGCG CGTGGCTGAA GGCACCCAGG TGCTTGAGTT GCCCTTCAA 900  
 GGTGATGACA TCACCATGGT CCTCATCTTG CCCAAGCCTG AGAAGAGCCT GGCCAAGGTG 960  
 GAGAAGGAAC TCACCCAGA GGTGCTGCAG GAGTGGCTGG ATGAATTGGA GGAGATGATG 1020  
 CTGGTGGTTC ACATGCCCCG CTTCCGCATT GAGGACGGCT TCAGTTTGAA GGAGCAGCTG 1080  
 40 CAAGACATGG GCCTGTCTGA TCTGTTTCA CCGTAAAAGT CCAAACCTCC AGGTATTGTT 1140  
 GCAGAAGGCC GAGATGACCT CTATGTCTCA GATGCATTCC ATAAGGCATT TCTTGAGGTA 1200  
 AATGAAGAAG GCAGTGAAGC AGCTGCAAGT ACCGCTGTTG TGATTGCTGG CCGTTCGCTA 1260  
 AACCCCAACA GGTGACTTT CAAGGCCAAC AGGCCCTTCC TGGTTTTTAT AAGAGAAGTT 1320  
 CCTCTGAACA CTATTATCTT CATGGGCAGA GTAGCCAACC CTTGTGTAA GTAACCTCGAG 1380  
 45 CC 1382

(2) INFORMATION FOR SEQ ID NO:20:

50

(i) SEQUENCE CHARACTERISTICS:

- (A) LENGTH: 1940 base pairs.
- (B) TYPE: nucleic acid
- (C) STRANDEDNESS: single
- (D) TOPOLOGY: linear

55

(vii) IMMEDIATE SOURCE:

- (B) CLONE: codon-optimized 3D signal peptide-HSA DNA sequence

(xi) SEQUENCE DESCRIPTION: SEQ ID NO:20:

60 ATGAAGAACA CCTCCTCCCT CTGCCTCCTG CTGCTCGTGG TCCTCTGCTC CCTGACCTGC 60  
 AACAGCGGCC AGGCCAGATG CACACAAGAG TGAGGTTGCT CATCGGTTTA AAGATTTGGG 120  
 AGAAGAAAAT TTCAAAGCCT TGGTGTGAT TGCCTTTGCT CAGTATCTTC AGCAGTGTC 180  
 ATTTGAAGAT CATGTAAAT TAGTGAATGA AGTAACTGAA TTTGCAAAAA CATGTGTAGC 240  
 TGATGAGTCA GCTGAAAATT GTGACAAATC ACTTCATACC CTTTTTGGAG ACAAATTATG 300  
 65 CACAGTTGCA ACTCTTCGTG AAACCTATGG TGAATGGCT GACTGCTGTG CAAAACAAGA 360  
 ACCTGAGAGA AATGAATGCT TCTTGCAACA CAAAGATGAC AACCCAAACC TCCCCGATT 420  
 GGTGAGACCA GAGGTTGATG TGATGTGCAC TGCTTTTCAT GACAATGAAG AGACATTTT 480

	GAAAAAATAC	TTATATGAAA	TTGCCAGAAG	ACATCCTTAC	TTTTATGCC	CGGAACTCCT	540
	TTTCTTTGCT	AAAAGGTATA	AAGCTGCTTT	TACAGAATGT	TGCCAAGCTG	CTGATAAAGC	600
	TGCCCTGCC	TTGCCAAAGC	TCGATGAACT	TCGGGATGAA	GGGAAGGCTT	CGTCTGCCAA	660
	ACAGAGACTC	AAATGTGCCA	GTCTCCAAAA	ATTTGGAGAA	AGAGCTTTCA	AAGCATGGGC	720
5	AGTGGCTCGC	CTGAGCCAGA	GATTTCCCAA	AGCTGAGTTT	GCAGAAGTTT	CCAAGTTAGT	780
	GACAGATCTT	ACCAAAGTCC	ACACGGAATG	CTGCCATGGA	GATCTGCTTG	AATGTGCTGA	840
	TGACAGGGCG	GACCTTGCCA	AGTATATCTG	TGAAAATCAG	GATTCGATCT	CCAGTAAACT	900
	GAAGGAATGC	TGTGAAAAAC	CTCTGTTGGA	AAAATCCAC	TGCATTGCCG	AAGTGGAAAA	960
	TGATGAGATG	CCTGCTGACT	TGCCTTCATT	AGCTGCTGAT	TTTGTGAAA	GTAAGGATGT	1020
10	TTGCAAAAAC	TATGCTGAGG	CAAAGGATGT	CTTCCTGGGC	ATGTTTTTGT	ATGAATATGC	1080
	AAGAAGGCAT	CCTGATTACT	CTGTGCTGCT	GCTGCTGAGA	CTTGCCAAGA	CATATGAAAC	1140
	CACTCTAGAG	AAGTGTCTGT	CCGCTGCAGA	TCCTCATGAA	TGCTATGCCA	AAGTGTTCGA	1200
	TGAATTTAAA	CCTCTTGTGG	AAGAGCCTCA	GAATTTAATC	AAACAAAAC	GTGAGCTTTT	1260
	TAAGCAGCTT	GGAGAGTACA	AATTCCAGAA	TGCGCTATTA	GTTTCGTTACA	CCAAGAAAGT	1320
15	ACCCCAAGTG	TCAACTCCAA	CTCTTGTAGA	GGTCTCAAGA	AACCTAGGAA	AAGTGGGCAG	1380
	CAAATGTTGT	AAACATCCTG	AAGCAAAAAG	AATGCCCTGT	GCAGAAGACT	ATCTATCCGT	1440
	GGTCCTGAAC	CAGTTATGTG	TGTTGCATGA	GAAAACGCCA	GTAAGTGACA	GAGTCACAAA	1500
	ATGCTGCACA	GAGTCCTTGG	TGAACAGGCG	ACCATGCTTT	TCAGCTCTGG	AAGTCGATGA	1560
	AACATACGTT	CCCAAAGAGT	TTAATGCTGA	AACATTCACC	TTCCATGCAG	ATATATGCAC	1620
20	ACTTTCTGAG	AAGGAGAGAC	AAATCAAGAA	ACAACTGCA	CTTGTTGAGC	TTGTGAAACA	1680
	CAAGCCCAAG	GCAACAAAAG	AGCAACTGAA	AGCTGTTATG	GATGATTTTCG	CAGCTTTTGT	1740
	AGAGAAGTGC	TGCAAGGCTG	ACGATAAGGA	GACCTGCTTT	GCCGAGGAGG	GTA AAAA ACT	1800
	TGTTGCTGCA	AGTCAAGCTG	CCTTAGGCTT	ATAACATCTA	CATTTAAAAG	CATCTCAGCC	1860
	TACCATGAGA	ATAAGAGAAA	GAAAATGAAG	ATCAAAAGCT	TATTCATCTG	TTTTCTTTTT	1920
25	CGTTGGTGTA	AAGCCAACAC					1940

(2) INFORMATION FOR SEQ ID NO:21:

(i) SEQUENCE CHARACTERISTICS:  
 (A) LENGTH: 1140 base pairs  
 (B) TYPE: nucleic acid  
 (C) STRANDEDNESS: single  
 (D) TOPOLOGY: linear

(vii) IMMEDIATE SOURCE:  
 (B) CLONE: codon-optimized 3D signal peptide-BPN' DNA sequene

(xi) SEQUENCE DESCRIPTION: SEQ ID NO:21:

40	ATGAAGAACA	CCTCCTCCCT	CTGCCTCCTG	CTGCTCGTGG	TCCTCTGCTC	CCTGACCTGC	60
	AACAGCGGCC	AGGCCGCTGG	CAAGAGCAAC	GGGGAGAAGA	AGTACATCGT	CGGCTTCAAG	120
	CAGACCATGA	GCACCATGAG	CGCCGCCAAG	AAGAAGGACG	TCATCAGCGA	GAAGGGCGGC	180
	AAGGTACAGA	AGCAGTTCAA	GTACGTGGAC	GCCGCCAGCG	CCACCCTCAA	CGAGAAGGCC	240
	GTCAAGGAGC	TGAAGAAGGA	CCCGAGCGTC	GCCTACGTCC	AGGAGGACCA	CGTCGCCCAC	300
45	GCATATGCAC	AGAGCGTCCC	GTACGGCGTC	AGCCAGATCA	AGGCCCCGGC	CCTCCACAGC	360
	CAGGGCTACA	CCGGCAGCAA	CGTCAAGGTC	GCCGTCATCG	ACAGCGGCAT	CGACAGCAGC	420
	CACCCGGACC	TCAAGGTCGC	CGGCGGAGCT	AGCATGGTCC	CGAGCGAGAC	CAACCCGTTT	480
	CAGGACACCA	ACAGCCATGG	CACCCACGTC	GCCGGCACCG	TCGCCGCCCT	CACCAACAGC	540
	ATCGGCGTCC	TCGGCGTCGC	CCCGAGCGCC	AGCCTCTACG	CCGTCAAGGT	ACTCGGCGCC	600
50	GACGGCAGCG	GCCAGTACAG	CTGGATCATC	AACGGCATCG	AGTGGGCCAT	CGCCAACAAC	660
	ATGGACGTCA	TCACCATGAG	CCTCGGCCGC	CCGAGCGGCA	GCGCCGCCCT	CAAGGCCGCC	720
	GTCGACAAGG	CCGTCGCCAG	CGGCGTCGTC	GTCGTCGCCG	CCGCCGGCAA	CGAGGGCACC	780
	AGCGGCAGCA	GCAGCACCGT	CGGCTACCCG	GGCAAGTACC	CGAGCGTCAT	CGCCGTCGGC	840
	GCCGTGGACA	GCAGCAACCA	GCGCGCGAGC	TTCAGCAGCG	TCGGCCCGGA	GCTGGACGTC	900
55	ATGGCCCCGG	GCGTCAGCAT	CCAGAGCACC	CTCCCGGGCA	ACAAGTACGG	CGCCTACAGC	960
	GGCACCAGCA	TGGCCAGCCC	GCACGTCGCG	GGCGCCGCTG	CACTCATCCT	CAGCAAGCAC	1020
	CCGACCTGGA	CCAACACCCA	GGTCCGCAGC	AGCCTGGAGA	ACACCACCAC	CAAGCTCGGC	1080
	GACAGCTTCT	ACTACGGCAA	GGGCCTCATC	AACGTCCAGG	CCGCCGCCCA	GTGACTCGAG	1140

60 (2) INFORMATION FOR SEQ ID NO:22:

(i) SEQUENCE CHARACTERISTICS:  
 (A) LENGTH: 13 amino acids  
 (B) TYPE: amino acid  
 (D) TOPOLOGY: linear

(ii) MOLECULE TYPE: peptide



(vii) IMMEDIATE SOURCE:  
(B) CLONE: N-terminus of mature AAT

(xi) SEQUENCE DESCRIPTION: SEQ ID NO:22:

5  
Glu Asp Pro Gln Gly Asp Ala Ala Gln Lys Thr Asp Thr  
1 5 10

(2) INFORMATION FOR SEQ ID NO:23:

10 (i) SEQUENCE CHARACTERISTICS:

- (A) LENGTH: 30 base pairs  
(B) TYPE: nucleic acid  
(C) STRANDEDNESS: single  
15 (D) TOPOLOGY: linear

(xi) SEQUENCE DESCRIPTION: SEQ ID NO:23:

20 GCTTGACCTG TAACTCGGGC CAGGCGAGCT 30

(2) INFORMATION FOR SEQ ID NO:24:

25 (i) SEQUENCE CHARACTERISTICS:

- (A) LENGTH: 30 base pairs  
(B) TYPE: nucleic acid  
(C) STRANDEDNESS: single  
(D) TOPOLOGY: linear

30 (xi) SEQUENCE DESCRIPTION: SEQ ID NO:24:

CGCCTAGCCC GAGTTACAGG TCAAGCAGCT 30

(2) INFORMATION FOR SEQ ID NO:25:

35 (i) SEQUENCE CHARACTERISTICS:

- (A) LENGTH: 37 base pairs  
(B) TYPE: nucleic acid  
40 (C) STRANDEDNESS: single  
(D) TOPOLOGY: linear

(xi) SEQUENCE DESCRIPTION: SEQ ID NO:25:

45 AGCTCCATGG CCGTGGCTCG AGTCTAGACG CGTCCCC 37

(2) INFORMATION FOR SEQ ID NO:26:

50 (i) SEQUENCE CHARACTERISTICS:

- (A) LENGTH: 33 base pairs  
(B) TYPE: nucleic acid  
(C) STRANDEDNESS: single  
55 (D) TOPOLOGY: linear

(xi) SEQUENCE DESCRIPTION: SEQ ID NO:26:

60 GGGGACGCGT CTAGACTCGA GCCACGGCCA TGG 33

(2) INFORMATION FOR SEQ ID NO:27:

65 (i) SEQUENCE CHARACTERISTICS:

- (A) LENGTH: 35 base pairs  
(B) TYPE: nucleic acid  
(C) STRANDEDNESS: single  
(D) TOPOLOGY: linear

(xi) SEQUENCE DESCRIPTION: SEQ ID NO:27:  
5 GCATGCAGGT GCTGAACACC ATGGTGAACA AACAC 35

(2) INFORMATION FOR SEQ ID NO:28:

(i) SEQUENCE CHARACTERISTICS:  
10 (A) LENGTH: 32 base pairs  
(B) TYPE: nucleic acid  
(C) STRANDEDNESS: single  
(D) TOPOLOGY: linear

(xi) SEQUENCE DESCRIPTION: SEQ ID NO:28:  
15 TTCTTGTCCT TTTTCGGTCCT CATCGTCCTC CT 32

(2) INFORMATION FOR SEQ ID NO:29:

(i) SEQUENCE CHARACTERISTICS:  
20 (A) LENGTH: 32 base pairs  
(B) TYPE: nucleic acid  
25 (C) STRANDEDNESS: single  
(D) TOPOLOGY: linear

(xi) SEQUENCE DESCRIPTION: SEQ ID NO:29:  
30 TGGCCTCTCC TCCAATTGA CAGCCGGGAG CT 32

(2) INFORMATION FOR SEQ ID NO:30:

(i) SEQUENCE CHARACTERISTICS:  
35 (A) LENGTH: 32 base pairs  
(B) TYPE: nucleic acid  
(C) STRANDEDNESS: single  
(D) TOPOLOGY: linear

(xi) SEQUENCE DESCRIPTION: SEQ ID NO:30:  
40 TTCACCATGG TGTTTCAGCAC CTGCATGCTG CA 32

(2) INFORMATION FOR SEQ ID NO:31:

(i) SEQUENCE CHARACTERISTICS:  
45 (A) LENGTH: 32 base pairs  
(B) TYPE: nucleic acid  
50 (C) STRANDEDNESS: single  
(D) TOPOLOGY: linear

(xi) SEQUENCE DESCRIPTION: SEQ ID NO:31:  
55 CGATGAGGAC CGAAAGGGAC AAGAAGTGTT TG 32

(2) INFORMATION FOR SEQ ID NO:32:

(i) SEQUENCE CHARACTERISTICS:  
60 (A) LENGTH: 35 base pairs  
(B) TYPE: nucleic acid  
(C) STRANDEDNESS: single  
65 (D) TOPOLOGY: linear

(xi) SEQUENCE DESCRIPTION: SEQ ID NO:32:

CCCGGCTGTC AAGTTGGAGG AGAGGCCAAG GAGGA

35

(2) INFORMATION FOR SEQ ID NO:33:

5

- (i) SEQUENCE CHARACTERISTICS:
  - (A) LENGTH: 29 base pairs
  - (B) TYPE: nucleic acid
  - (C) STRANDEDNESS: single
  - (D) TOPOLOGY: linear

10

(xi) SEQUENCE DESCRIPTION: SEQ ID NO:33:

GAGGATCCCC AGGGAGATGC TGCCCAGAA

29

15

(2) INFORMATION FOR SEQ ID NO:34:

20

- (i) SEQUENCE CHARACTERISTICS:
  - (A) LENGTH: 34 base pairs
  - (B) TYPE: nucleic acid
  - (C) STRANDEDNESS: single
  - (D) TOPOLOGY: linear

25

(xi) SEQUENCE DESCRIPTION: SEQ ID NO:34:

CGCGCTCGAG TTATTTTGG GTGGGATTCA CCAC

34

**IT IS CLAIMED:**

1. A method of producing, in monocot plant cells, a mature heterologous protein selected from the group consisting of

5 (i) mature, glycosylated  $\alpha_1$ -antitrypsin (AAT) having the same N-terminal amino acid sequence as mature AAT produced in humans and a glycosylation pattern which increases serum half-life substantially over that of mature non-glycosylated AAT;

(ii) mature, glycosylated antithrombin III (ATIII) having the same N-terminal amino acid sequence as mature ATIII produced in humans;

10 (iii) mature human serum albumin (HSA) having the same N-terminal amino acid sequence as mature HSA produced in humans and having the folding pattern of native mature HSA as evidenced by its bilirubin-binding characteristics; and

(iv) mature, active subtilisin BPN' (BPN') having the same N-terminal amino acid sequence as BPN' produced in *Bacillus*;

15 the method comprising:

(a) obtaining monocot cells transformed with a chimeric gene having (i) a monocot transcriptional regulatory region, inducible by addition or removal of a small molecule, or during seed maturation, (ii) a first DNA sequence encoding the heterologous protein, and (iii) a second DNA sequence encoding a signal peptide, said first and second DNA sequences in translation-frame and encoding a fusion protein, and wherein (i) the transcriptional regulatory region is operably  
20 linked to the second DNA sequence, and (ii) said signal peptide is effective to facilitate secretion of the mature heterologous protein from the transformed cells;

(b) cultivating the transformed cells under conditions effective to induce said transcriptional regulatory region, thereby promoting expression of the fusion protein and secretion of the mature  
25 heterologous protein from the transformed cells; and

(c) isolating said mature heterologous protein produced by the transformed cells.

2. The method of claim 1, wherein said first DNA sequence encodes proBPN', said cultivating includes cultivating said transformed cells at a pH between 5-6 to promote expression  
30 and secretion of proBPN' from the cells, and said isolating step includes incubating the proBPN' under conditions effective to allow the autoconversion of proBPN' to active mature BPN'.

3. The method of claim 1, wherein said first DNA sequence encodes mature BPN', and said method further includes:

35 transforming said cells with a second chimeric gene containing (i) a transcriptional

regulatory region inducible by addition or removal of a small molecule, or during seed maturation,  
(ii) a third DNA sequence encoding the pro-peptide moiety of BPN', and (iii) a fourth DNA  
sequence encoding a signal polypeptide, where said fourth DNA sequence is operably linked to said  
transcriptional regulatory region and said third DNA sequence, and where said signal polypeptide is  
5 in translation-frame with said pro-peptide moiety and is effective to facilitate secretion of expressed  
pro-peptide moiety from the transformed cells;

said cultivating step includes cultivating the transformed cells at a pH between 5-6 to  
promote expression and secretion of BPN' and the pro-peptide moiety from the cells;

and said isolating step includes incubating the BPN' and the pro-moiety under conditions  
10 effective to allow the conversion of BPN' to active mature BPN', and isolating the active mature  
BPN'.

4. The method of claim 1, wherein said signal peptide is the RAmy3D signal peptide having  
the amino acid sequence identified by SEQ ID NO:1.

15

5. The method of claim 1, wherein said second DNA sequence encodes the RAmy3D signal  
peptide (SEQ ID NO:1) and has the codon-optimized nucleotide sequence identified by SEQ ID  
NO:3.

20 6. The method of claim 1, wherein said signal peptide is the RAmy1A signal peptide having  
the amino acid sequence identified by SEQ ID NO:4.

7. The method of claim 1, wherein the second DNA sequence, the first DNA sequence, or  
both the second and the first DNA sequence, is codon-optimized for enhanced expression in said  
25 plant.

8. The method of claim 1, wherein said transcriptional regulatory region is a promoter  
derived from a rice or barley  $\alpha$ -amylase gene selected from the group consisting of the RAmy1A,  
RAmy1B, RAmy2A, RAmy3A, RAmy3B, RAmy3C, RAmy3D, and RAmy3E, pM/C, gKAmy141,  
30 gKAmy155, Amy32b, and HV18 genes.

9. The method of claim 8, wherein the chimeric gene further comprises, between said  
transcriptional regulatory region and said second DNA coding sequence, the 5' untranslated region  
of an inducible monocot gene selected from the group consisting of RAmy1A, RAmy3B, RAmy3C,  
35 RAmy3D, HV18, and RAmy3E.

10. The method of claim 8, wherein said chimeric gene further comprises, downstream of the sequence encoding said fusion protein, the 3' untranslated region of an inducible monocot gene derived from a rice or barley  $\alpha$ -amylase gene selected from the group consisting of the RAmy1A, 5 RAmy1B, RAmy2A, RAmy3A, RAmy3B, RAmy3C, RAmy3D, and RAmy3E, pM/C, gKAmly141, gKAmly155, Amy32b, and HV18 genes.

11. The method of claim 1, wherein said cultivating includes culturing the transformed plant cells in a sugar-free or sugar-depleted medium, the transcriptional regulatory region is derived from 10 the RAmy3E or RAmy3D gene, the 5' untranslated region is derived from the RAmy1A gene and has the sequence identified by SEQ ID NO:5, and the 3' untranslated region is derived from the RAmy1A gene.

12. The method of claim 1, wherein the transformed cells are aleurone cells of mature 15 seeds, the transcriptional regulatory region is upregulated by addition of a small molecule to promote seed germination, and said cultivating includes germinating said seeds, either in embryonated or de-embryonated form.

13. The method of claim 12, wherein the transcriptional regulatory region is a rice  $\alpha$ - 20 amylase RAmy1A promoter or a barley HV18 promoter, and said small molecule is gibberellic acid.

14. A mature heterologous protein produced by the method of claim 1, wherein said protein is selected from the group consisting of:

(i) mature glycosylated  $\alpha_1$ -antitrypsin (AAT) having the same N-terminal amino acid 25 sequence as mature AAT produced in humans and having a glycosylation pattern which increases serum half-life substantially over that of non-glycosylated mature AAT;

(ii) mature glycosylated antithrombin III (ATIII) having the same N-terminal amino acid sequence as mature ATIII produced in humans; and

(iii) mature glycosylated subtilisin BPN' (BPN') having the same N-terminal amino acid 30 sequence as BPN' produced in *Bacillus*;

wherein said protein has a glycosylation pattern characteristic of proteins produced in said monocot plant.

15. The method of claim 1, wherein said monocot plant cells are transformed rice, barley, 35 corn, wheat, oat, rye, sorghum, or millet cells.

16. The method of claim 1, wherein said monocot plant cells are transformed rice or barley cells.

5 17. Plant cells capable of producing the mature heterologous protein according to the method of claim 1, wherein said cultivating includes culturing the transformed plant cells in a sugar-free or sugar-depleted medium, the transcriptional regulatory region is derived from the RAmy3E or RAmy3D gene, the 5' untranslated region is derived from the RAmy1A gene and has the sequence identified by SEQ ID NO:5, and the 3' untranslated region is derived from the RAmy1A gene.

10

18. Seeds capable of producing the mature heterologous protein according to the method of claim 1, wherein said transformed cells are aleurone cells, the transcriptional regulatory region is upregulated by addition of a small molecule to promote seed germination, and said cultivating includes germinating said seeds, either in embryonated or de-embryonated form.

15

3D Signal Peptide

non-codon optimized ATG AAG AAC ACC AGC AGC TTG TGT TTG CTG CTC CTC GTG GTG CTC TGC AGC TTG ACC TGT AAC TCG GGC CAG GCG  
 codon-optimized ATG AAG AAC ACC TCC TCC CTC CTC CTG CTC CTC GTG GTC CTC TGC TCC CTG ACC TGC AAC AGC GGC CAG GCG  
 amino acid sequence Met Lys Asn Thr Ser Ser Leu Cys Leu Leu Leu Val Val Leu Cys Ser Leu Thr Cys Asn Ser Gly Gln Ala

Fig. 1

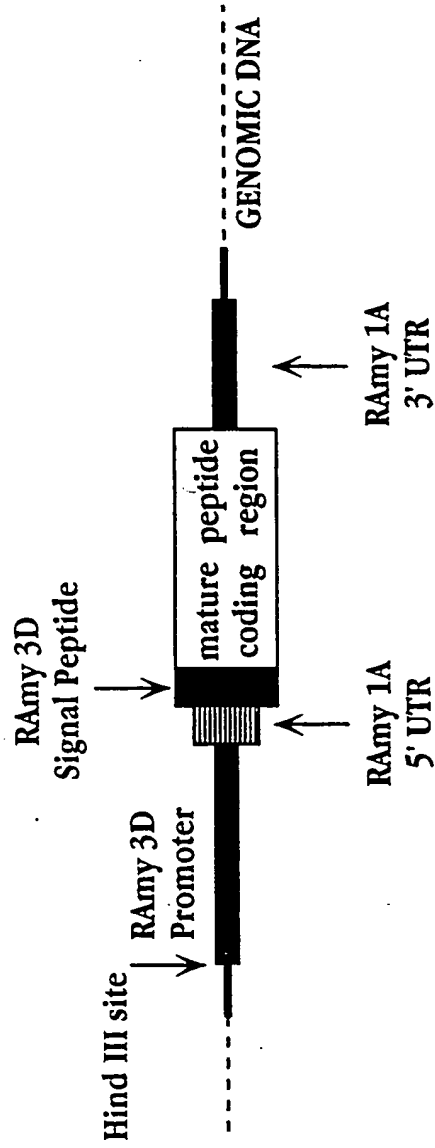
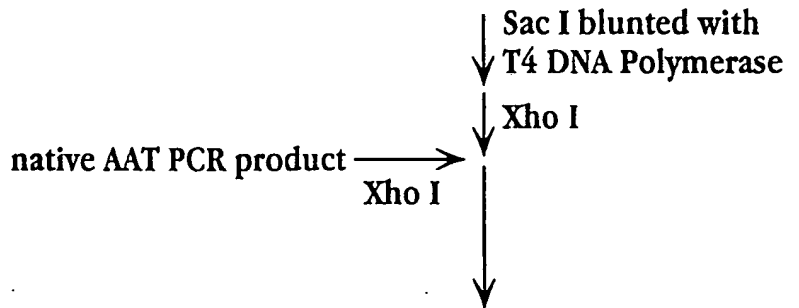
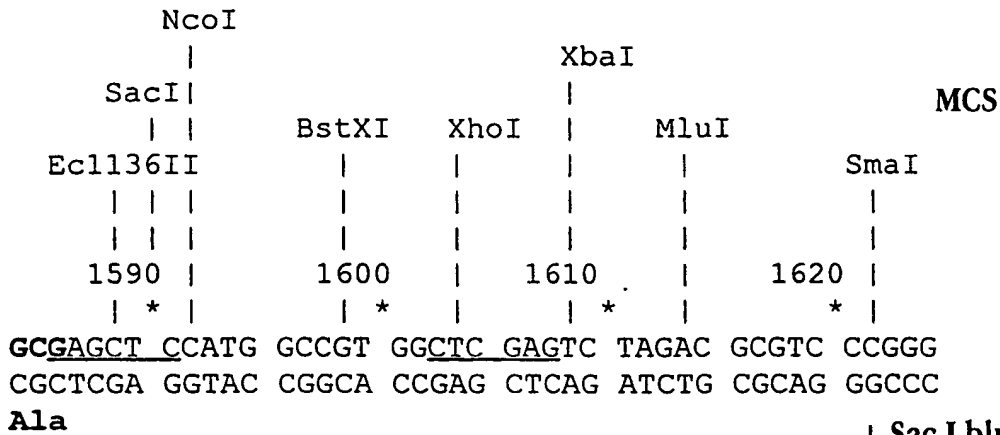
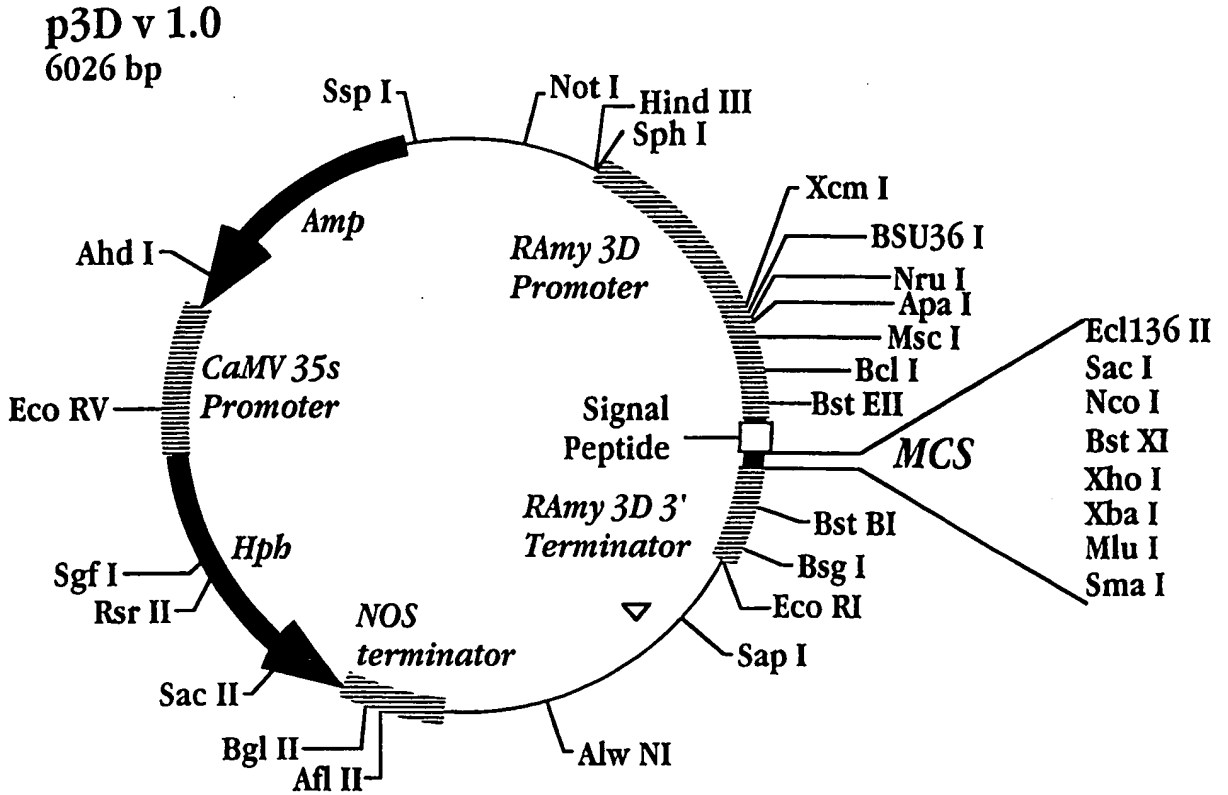

Fig. 2





**Fig. 3A**

p3D - AAT  
7195 bp

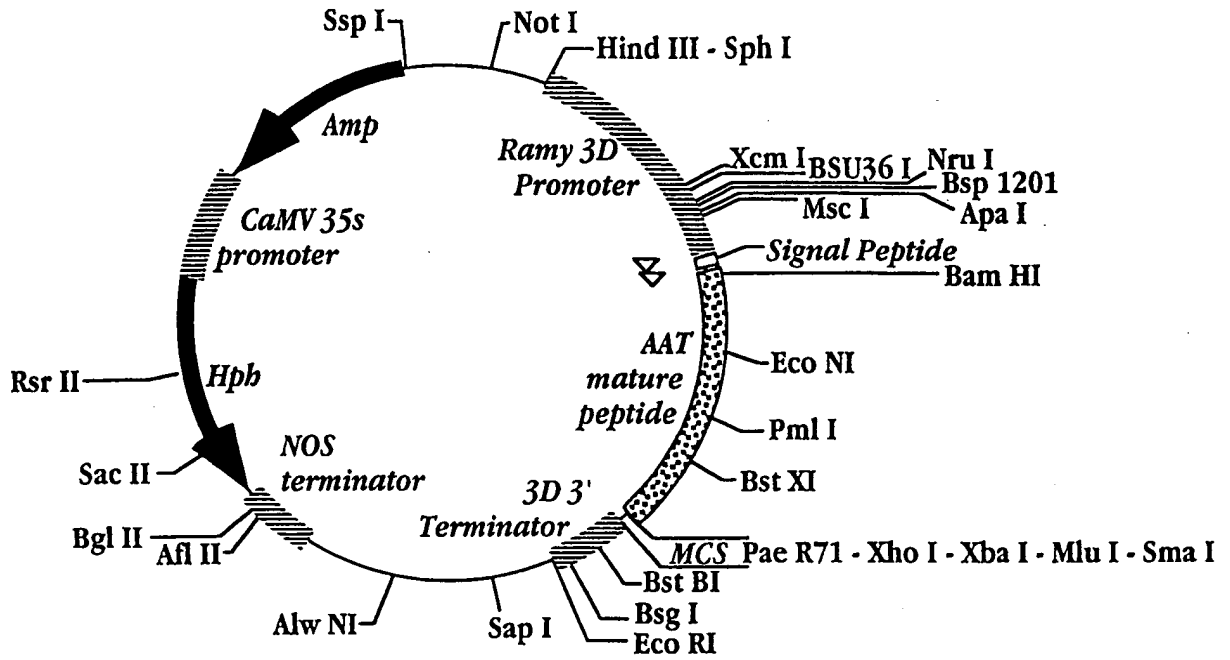

Fig. 3B

4/11

Molecular Weight Ladder

Phosphate		- Sucrose		+ Sucrose		$\alpha_1$ AT
+E	-E	+E	-E	+E	-E	

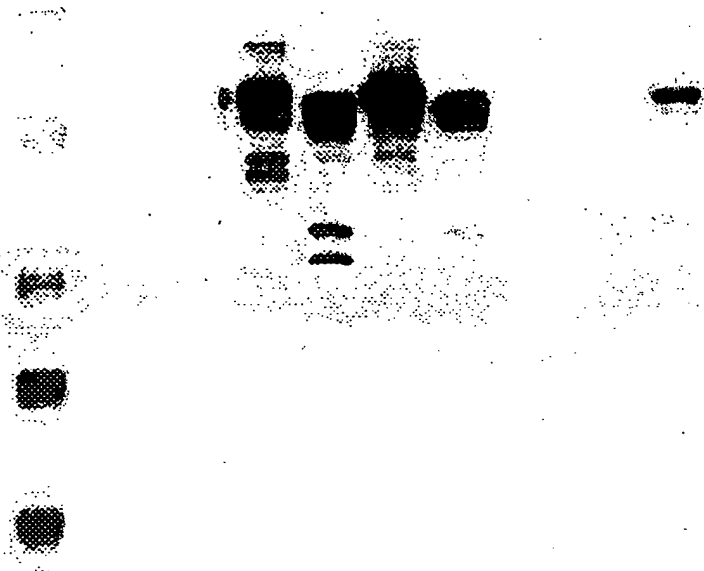
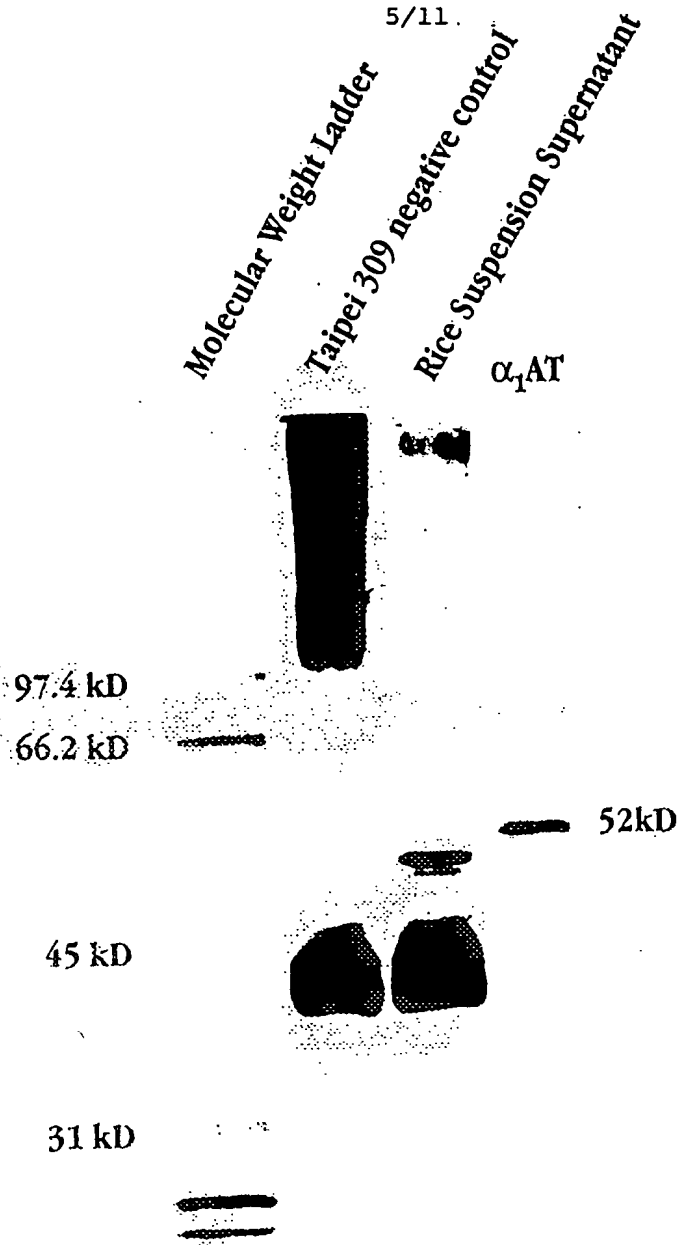

Fig. 4



**Fig. 5**

6/11

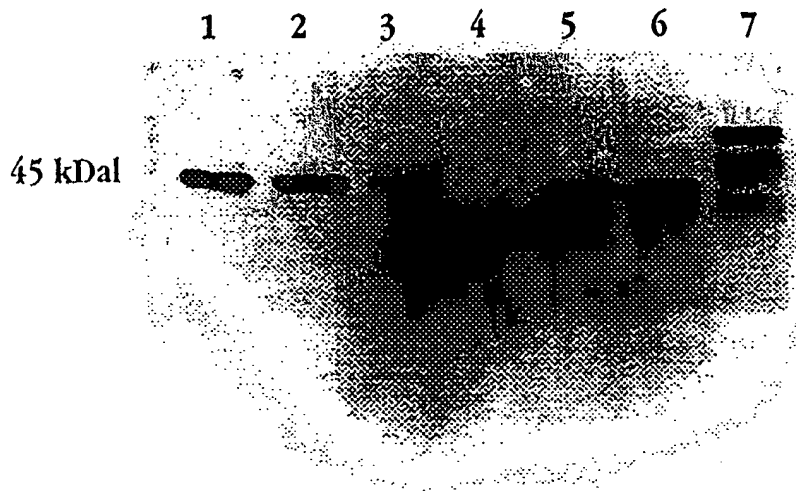

Fig. 6



Fig. 7

N ----> E-D-P-Q-G-D-A-A-Q-K-T-D-T

Fig. 8

8/11

TP309 - sucrose  
TP309 + sucrose  
9A - sucrose  
9A + sucrose  
32B - sucrose  
32B + sucrose  
46 - sucrose  
46 + sucrose  
42 + sucrose  
42 + sucrose  
Mol. Weight  
AT III (1ng)

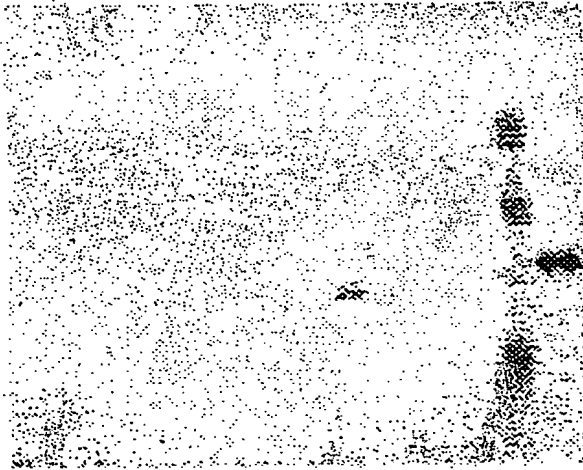

Fig. 9

9/11

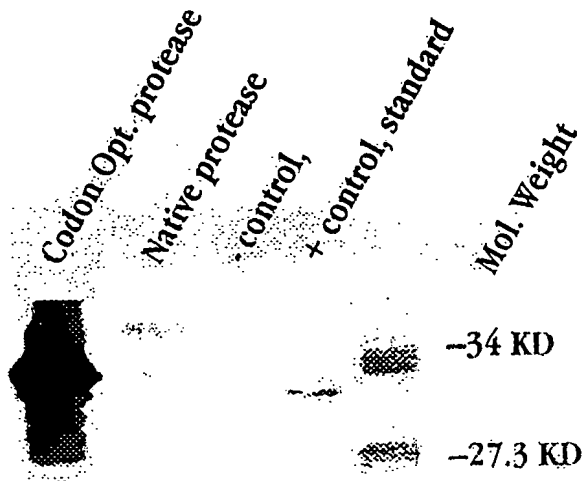
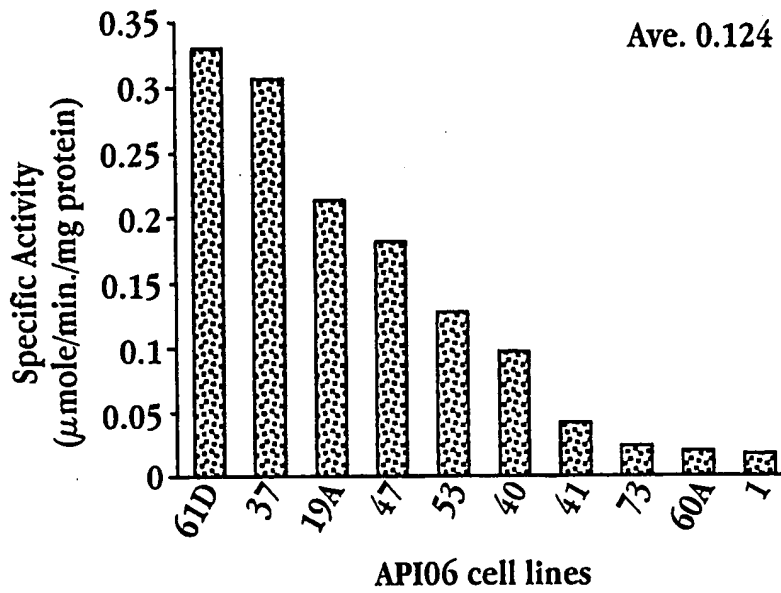
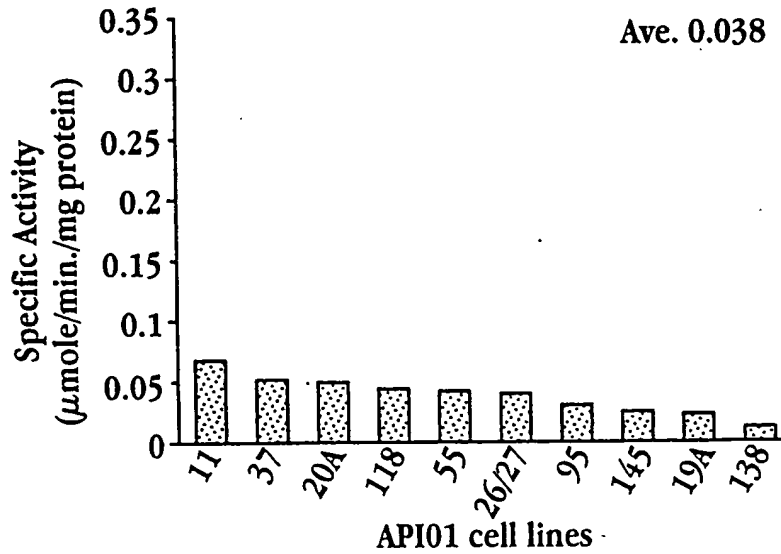

Fig. 10





**Fig. 11A**



**Fig. 11B**

11/11

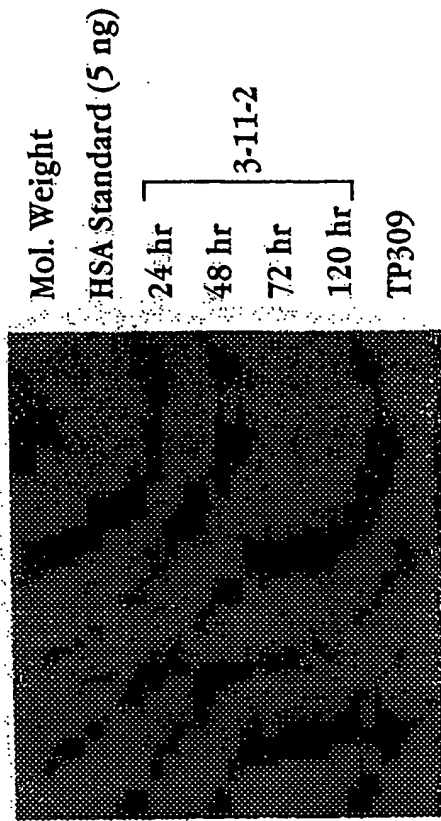

Fig. 12

**A. CLASSIFICATION OF SUBJECT MATTER**  
 IPC 6 C12N15/82 C12N15/57 C12N15/15 C12N15/14 C12P21/02

According to International Patent Classification (IPC) or to both national classification and IPC

**B. FIELDS SEARCHED**  
 Minimum documentation searched (classification system followed by classification symbols)  
 IPC 6 C12N C12P

Documentation searched other than minimum documentation to the extent that such documents are included in the fields searched

Electronic data base consulted during the international search (name of data base and, where practical, search terms used)

**C. DOCUMENTS CONSIDERED TO BE RELEVANT**

Category *	Citation of document, with indication, where appropriate, of the relevant passages	Relevant to claim No.
X	WO 95 14099 A (RODRIGUEZ RAYMOND L ;UNIV CALIFORNIA (US)) 26 May 1995	1,4,6,8-18
Y	see the whole document	1,5
Y	WO 92 01042 A (NOVONORDISK AS) 23 January 1992 see page 6, line 15 - line 19	1
Y	JENSEN L G ET AL: "TRANSGENIC BARLEY EXPRESSING A PROTEIN-ENGINEERED, THERMOSTABLE (1,3-1,4)-BETA-FLUCANASE DURING GERMINATION" PROCEEDINGS OF THE NATIONAL ACADEMY OF SCIENCES OF USA, vol. 93, no. 8, April 1996, pages 3487-3491, XP002024710 see the whole document	5

Further documents are listed in the continuation of box C.  Patent family members are listed in annex.

\* Special categories of cited documents :

<p>"A" document defining the general state of the art which is not considered to be of particular relevance</p> <p>"E" earlier document but published on or after the international filing date</p> <p>"L" document which may throw doubts on priority claim(s) or which is cited to establish the publication date of another citation or other special reason (as specified)</p> <p>"O" document referring to an oral disclosure, use, exhibition or other means</p> <p>"P" document published prior to the international filing date but later than the priority date claimed</p>	<p>"T" later document published after the international filing date or priority date and not in conflict with the application but cited to understand the principle or theory underlying the invention</p> <p>"X" document of particular relevance; the claimed invention cannot be considered novel or cannot be considered to involve an inventive step when the document is taken alone</p> <p>"Y" document of particular relevance; the claimed invention cannot be considered to involve an inventive step when the document is combined with one or more other such documents, such combination being obvious to a person skilled in the art.</p> <p>"&amp;" document member of the same patent family</p>
--	--

Date of the actual completion of the international search <b>30 June 1998</b>	Date of mailing of the international search report <b>14/07/1998</b>
--	---

Name and mailing address of the ISA European Patent Office, P.B. 5818 Patentlaan 2 NL - 2280 HV Rijswijk Tel. (+31-70) 340-2040, Tx. 31 651 epo nl, Fax: (+31-70) 340-3016	Authorized officer <b>Maddox, A</b>
--	--

## C.(Continuation) DOCUMENTS CONSIDERED TO BE RELEVANT

Category *	Citation of document, with indication, where appropriate, of the relevant passages	Relevant to claim No.
P,X	TERASHIMA M ET AL: "Production of functional human alpha-1-antitrypsin by rice cell culture; expression and protein secretion in callus culture (conference abstract)" ABSTR.PAP.AM.CHEM.SOC.;(1997) 214 MEET., PT.1, AGFD018 CODEN: ACSRAL ISSN: 0065-7727 AMERICAN CHEMICAL SOCIETY, 214TH ACS NATIONAL MEETING, LAS VEGAS, NV, 7-11 SEPTEMBER, 1997., XP002069835 see abstract 018	1,4, 8-10, 14-17
A	THOMAS, B. R. ET AL: "Gene regulation and protein secretion from plant cell cultures: the rice alpha - amylase system" ADVANCES IN PLANT BIOTECHNOLOGY, (1994) PP. 37-55. STUDIES IN PLANT SCIENCE 4. 85 REF. PUBLISHER: ELSEVIER SCIENCE. AMSTERDAM ISBN: 0-444-89939-1, XP002069833 see the whole document	1,11
A	CHAN M-T ET AL: "Novel gene expression system for plant cells based on induction of alpha-amylase promoter by carbohydrate starvation." JOURNAL OF BIOLOGICAL CHEMISTRY 269 (26). 1994. 17635-17641. ISSN: 0021-9258, XP002069821 see the whole document	1,11
A	US 5 460 952 A (YU SU-MAY ET AL) 24 October 1995 see the whole document	1,11
A	WO 90 01551 A (ROGERS JOHN C) 22 February 1990 see the whole document	1,12
A	WO 91 02066 A (MOGEN INT) 21 February 1991 see the whole document	1
A	EP 0 348 348 A (CIBA GEIGY AG) 27 December 1989 see examples 41-45	1

Patent document cited in search report	Publication date	Patent family member(s)	Publication date
WO 9514099 A	26-05-1995	US 5693506 A	02-12-1997
		AU 1289295 A	06-06-1995
		CA 2176834 A	26-05-1995
		EP 0788550 A	13-08-1997
		JP 9509565 T	30-09-1997
WO 9201042 A	23-01-1992	AU 8219291 A	04-02-1992
US 5460952 A	24-10-1995	JP 7143895 A	06-06-1995
		US 5712112 A	27-01-1998
WO 9001551 A	22-02-1990	AU 638409 B	01-07-1993
		AU 4037289 A	05-03-1990
		EP 0428572 A	29-05-1991
		JP 4500153 T	16-01-1992
		US 5677474 A	14-10-1997
WO 9102066 A	21-02-1991	NL 8901932 A	18-02-1991
		EP 0436003 A	10-07-1991
		JP 4502861 T	28-05-1992
		US 5650307 A	22-07-1997
		US 5716802 A	10-02-1998
		US 5763748 A	09-06-1998
EP 0348348 A	27-12-1989	AU 631551 B	03-12-1992
		AU 3656889 A	21-12-1989
		DK 302289 A	28-02-1990
		IL 90640 A	04-01-1998
		JP 2046238 A	15-02-1990